

# WR13 WIPER SEAL

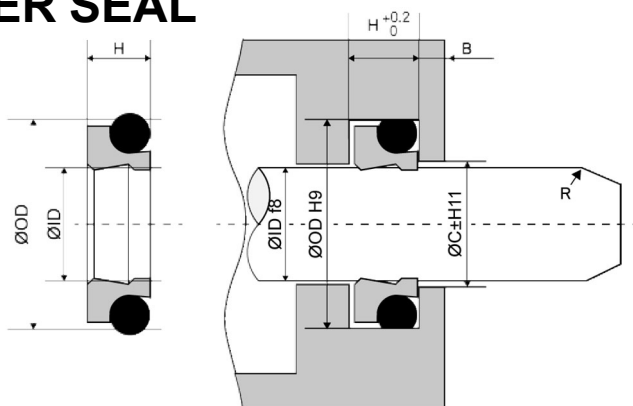

APPLICATION	
MATERIAL	PTFE + NBR
TEMP.	-30°C~100°C
SPEED	4m/s

ITEM	ID	OD	h	H	C	B
* WR13-035	35	42.6	3.9	4.2	36.5	2
* WR13-016	16	22.8	4.7	5	17.5	2
* WR13-018	18	24.8	4.7	5	19.5	2
WR13-020	20	26.8	4.7	5	21.5	2
WR13-022	22	28.8	4.7	5	23.5	2
* WR13-025	25	33	4.7	5	26.5	
* WR13-025	25	31.8	4.7	5	26.5	2
WR13-028	28	34.8	4.7	5	29.5	2
WR13-030	30	38	4.7	5	31.5	
* WR13-030	30	36.8	4.7	5	31.5	2
WR13-035	35	41.8	4.7	5	36.5	2
WR13-036	36	42.8	4.7	5	37.5	2
WR13-040	40	46.8	4.7	5	41.5	2
WR13-045	45	51.8	4.7	5	46.5	2
WR13-050	50	56.8	4.7	5	51.5	2
* WR13-050	50	58	4.7	5	51.5	
* WR13-055	55	61.8	4.7	5	56.5	2
WR13-056	56	62.8	4.7	5	57.5	2
* WR13-060	60	66.8	4.7	5	61.5	2
* WR13-063	63	69.8	4.7	5	64.5	2
* WR13-065	65	71.8	4.7	5	66.5	2
* WR13-080	80	90	5.7	6	81.5	3
WR13-100	100	108.8	5.7	6	101.5	3
* WR13-120	120	130	5.7	6	121.5	
WR13-065	65	73.8	6	6.3	66.5	
* WR13-070	70	78.8	6	6.3	71.5	3
* WR13-075	75	83.8	6	6.3	76.5	3
* WR13-080	80	88.8	6	6.3	81.5	3
* WR13-085	85	93.8	6	6.3	86.5	3
* WR13-090	90	98.8	6	6.3	91.5	3
* WR13-100	100	108.8	6	6.3	101.5	3
* WR13-125	125	133.8	6	6.3	126.5	3
* WR13-140	140	148.8	6	6.3	141.5	3
* WR13-080	80	90	6.7	7	81.5	
* WR13-075	75	87.2	7.8	8.1	76.5	
* WR13-080	80	92.2	7.8	8.1	82	4
* WR13-090	90	102.2	7.8	8.1	92	4
WR13-220	220	236	9.2	9.5	222.5	5