

DAS PISTON SEAL

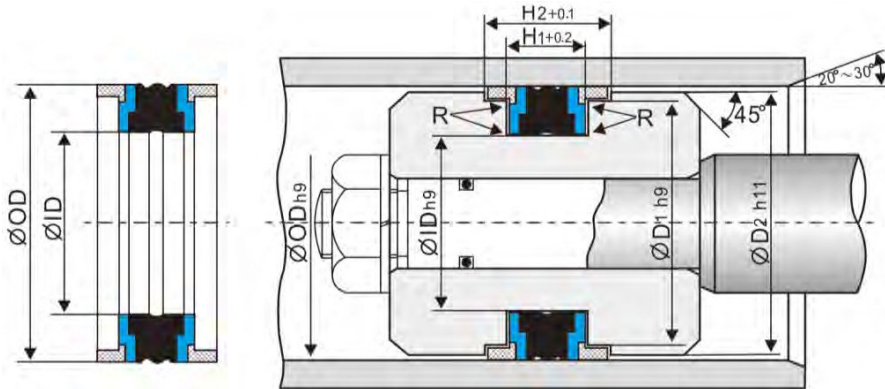

APPLICATION	
MATERIAL	POM+HY+NBR
TEMP.	-30°C~100°C
PRESSURE	400kgf/cm ²
SPEED	0.5m/s

ITEM	OD	ID	H1	H2	D1	D2
* DAS-020	20	11	13.5	17.7	17.00	19.0
* DAS-025	25	15	12	20	21.00	23.0
* DAS-025	25	15	16.4	29.1	21.45	23.5
* DAS-028	28	19	13.5	17.7	25.00	27.0
* DAS-030	30	21	13.5	17.7	27.00	29.0
DAS-032	32	22	15.5	20.7	28.00	31.0
* DAS-032	32	22	16.4	29.1	28.50	30.5
* DAS-035	35	25	15.5	20.7	31.00	34.0
* DAS-035	35	25	16.4	29.1	31.40	33.5
DAS-040	40	24	18.4	31.1	35.40	38.5
DAS-040	40	30	12.5	20.5	36.00	38.0
* DAS-040	40	30	16.4	29.1	35.40	38.5
* DAS-045	45	29	18.4	31.1	40.40	44.0
* DAS-045	45	31	15.5	20.7	41.00	44.0
* DAS-045	45	35	16.4	29.1	40.40	43.5
DAS-050	50	34	18.4	31.1	45.40	48.5
* DAS-050	50	34	20.5	26.7	46.00	49.0
DAS-050	50	38	20.5	28.9	46.00	49.0
DAS-055	55	39	18.4	31.1	50.36	53.5
* DAS-055	55	39	20.5	26.7	51.00	54.0
DAS-060	60	44	18.4	31.1	55.40	58.5
* DAS-060	60	44	20.5	26.7	56.00	59.0
DAS-063	63	47	18.4	31.1	58.40	61.5
DAS-063	63	47	19.4	32.1	58.40	61.5
DAS-063	63	47	20.5	26.7	59.00	62.0
* DAS-065	65	49	20.5	26.7	61.00	64.0
DAS-065	65	50	18.4	31.1	60.40	63.5
DAS-070	70	50	22.4	35.1	64.20	68.3
* DAS-070	70	54	20.5	26.7	66.00	69.0
DAS-075	75	55	22.4	35.1	69.20	73.3
DAS-080	80	60	22.4	35.1	74.15	78.3
DAS-080	80	62	22.4	29.7	76.00	79.0
DAS-085	85	65	22.4	35.1	79.15	83.3
DAS-090	90	70	22.4	35.1	84.15	88.3
* DAS-090	90	72	22.4	29.7	86.00	89.0
DAS-095	95	75	22.4	35.1	89.15	93.3

DAS PISTON SEAL

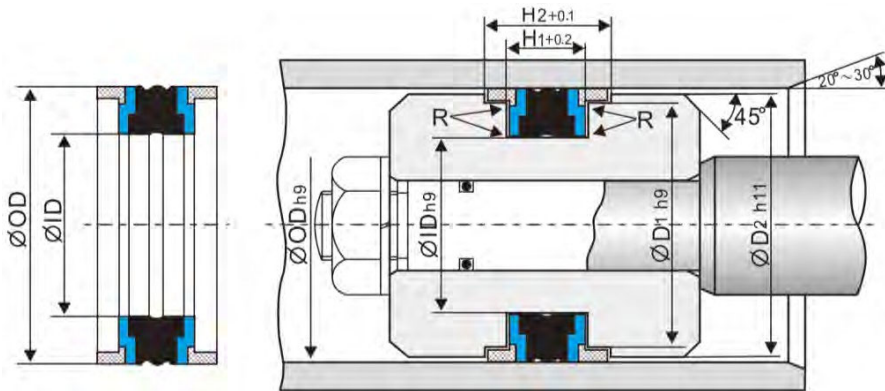

APPLICATION	
MATERIAL	POM+HY+NBR
TEMP.	-30°C~100°C
PRESSURE	400kgf/cm ²
SPEED	0.5m/s

ITEM	OD	ID	H1	H2	D1	D2
DAS-100	100	75	22.4	35.1	93.15	98.0
DAS-100	100	82	22.4	29.7	96.00	99.0
DAS-105	105	80	22.4	35.1	98.10	103.0
DAS-110	110	85	22.4	35.1	103.10	108.0
* DAS-110	110	92	22.4	29.7	106.00	109.0
DAS-115	115	90	22.4	35.1	108.10	113.0
* DAS-115	115	97	22.4	29.7	111.00	114.0
DAS-120	120	95	22.4	35.1	113.10	118.1
* DAS-120	120	106	22.4	32.9	116.00	118.5
DAS-125	125	100	25.4	38.1	118.10	123.0
* DAS-125	125	103	26.5	36.7	121.00	124.0
DAS-130	130	105	25.4	38.1	123.10	128.0
DAS-130	130	105	25.4	44.4	122.60	127.5
* DAS-135	135	110	25.4	38.1	128.10	133.0
DAS-135	135	110	25.4	44.4	127.60	132.5
DAS-140	140	115	25.4	38.1	133.00	138.0
DAS-140	140	115	25.4	44.4	132.60	137.5
* DAS-145	145	120	25.4	38.1	138.30	142.95
DAS-145	145	120	25.4	44.4	137.60	142.5
DAS-150	150	125	25.4	38.1	143.00	148.0
DAS-150	150	125	25.4	44.4	142.60	147.5
DAS-160	160	135	25.4	44.4	152.60	157.5
* DAS-160	160	138	26.5	36.7	156.00	159.0
* DAS-165	165	140	25.4	44.4	157.60	162.5
DAS-170	170	145	25.4	50.8	161.70	167.1
* DAS-175	175	150	25.4	50.8	166.70	172.1
* DAS-180	180	150	35.4	48.1	172.95	177.87
DAS-180	180	155	25.4	50.8	171.70	177.1
* DAS-185	185	160	25.4	50.8	176.70	182.1
DAS-200	200	175	25.4	50.8	191.60	197.0
* DAS-210	210	185	25.4	50.8	201.60	207.0
* DAS-215	215	190	25.4	50.8	206.60	214.0
* DAS-220	220	195	25.4	50.8	211.60	217.0
* DAS-250	250	225	25.4	50.8	241.60	247.0