

# UHS (UN/UNS) PISTON & ROD SEAL

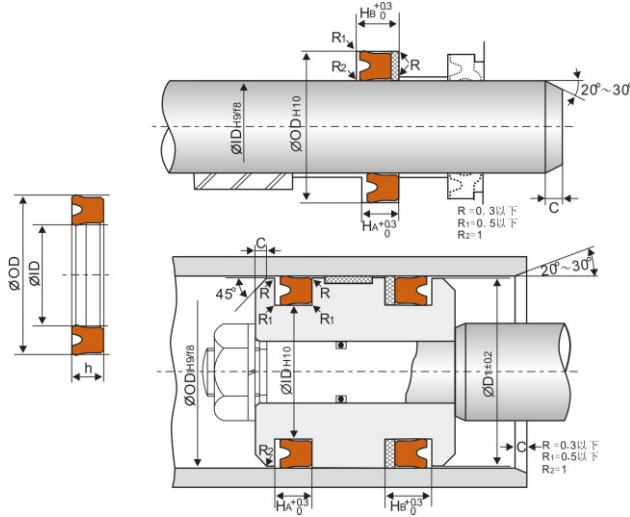

APPLICATION	
MATERIAL	PU
TEMP.	-35°C~100°C
PRESSURE	400kgf/cm <sup>2</sup>
SPEED	1m/s

ITEM	ID	OD	h	HA	HB	D1	C
* UHS-006.3	6.3	16.3	8	9	11	15.3	2.5
* UHS-007.1	7.1	17.1	8	9	11	16.1	2.5
UHS-008	8	18	8	9	11	17	2.5
* UHS-009	9	19	8	9	11	18	2.5
UHS-010	10	20	8	9	11	19	2.5
* UHS-011.2	11.2	21.2	8	9	11	20.2	2.5
UHS-012	12	25	8	9	11	24	2.5
* UHS-012.5	12.5	22.5	8	9	11	21.5	2.5
* UHS-014	14	24	8	9	11	23	2.5
UHS-015	15	25	8	9	11	24	2.5
UHS-016	16	26	8	9	11	25	2.5
* UHS-016	16	32	10	11	13	31	2.5
UHS-018	18	28	8	9	11	27	3.5
* UHS-018	18	31	10	11	13	30	3.5
UHS-020	20	30	8	9	11	29	3.5
* UHS-020	20	33	10	11	13	32	3.5
UHS-020	20	35	10	11	13	34	3.5
UHS-020	20	40	12				
* UHS-021.5	21.5	31.5	8	9	11	30.5	3.5
UHS-022	22	32	8	9	11	31	3.5
* UHS-022	22	35	10	11	13	34	3.5
* UHS-022.4	22.4	30	5	5.7	7.7	29	3.5
UHS-022.4	22.4	32.4	8	9	11	31.4	3.5
UHS-025	25	35	8	9	11	34	3.5
UHS-025	25	38	10				
UHS-025	25	40	10	11	13	39	3.5
* UHS-025	25	45	12	13	15	44	3.5
* UHS-025.5	25.5	35.5	8	9	11	34.5	3.5
* UHS-028	28	35.5	5	5.7	8.7	34.5	3.5
UHS-028	28	36	8				
UHS-028	28	40	10	11	14	39	3.5
* UHS-028	28	43	10	11	14	42	3.5

# UHS (UN/UNS) PISTON & ROD SEAL

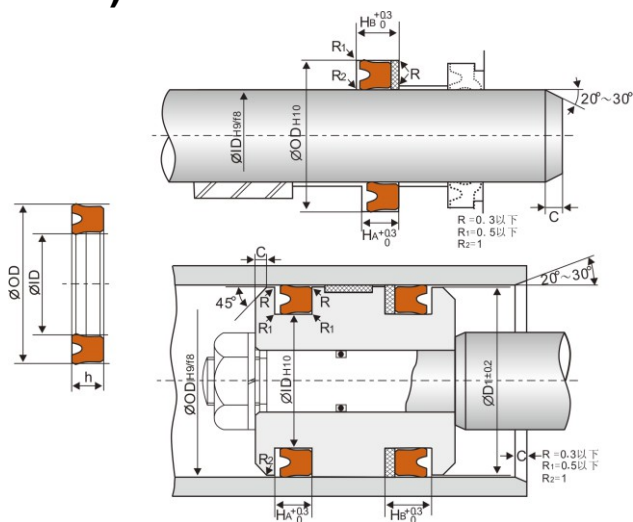

APPLICATION	
MATERIAL	PU
TEMP.	-35°C~100°C
PRESSURE	400kgf/cm <sup>2</sup>
SPEED	1m/s

ITEM	ID	OD	h	HA	HB	D1	C
UHS-030	30	40	10				
UHS-030	30	45	10	11	14	44	3.5
UHS-030	30	46	10	11	14	45	3.5
UHS-032	32	42	8				
* UHS-032	32	45	10				
UHS-032	32	45	11				
UHS-032	32	46	10	11	14	45	4
UHS-035	35	50	10	11	14	49	4
* UHS-035.5	35.5	45	6	7	10	44	4
* UHS-035.5	35.5	50.5	10	11	14	49.5	4
UHS-038	38	48	8				
UHS-038	38	52	10	11	14	51	4
UHS-038	38	55	10				
UHS-040	40	50	10				
* UHS-040	40	53	8				
* UHS-040	40	55	10	11	14	54	4
* UHS-040	40	56	10	11	14	55	4
UHS-040	40	60	12	13	16	59	4
* UHS-041	41	56	10	11	14	55	4
* UHS-045	45	56	7	8	11	55	4
UHS-045	45	60	10	11	14	59	4
* UHS-045	45	61	10	11	14	60	4
* UHS-046	46	60	10	11	14	59	4
UHS-048	48	63	10	11	14	62	4
UHS-050	50	60	10				
UHS-050	50	65	10	11	14	64	4
* UHS-050	50	66	12	13	16	65	4
* UHS-050	50	70	12	13	16	69	4
* UHS-051	51	71	12	13	16	70	4
* UHS-053	53	73	12	13	16	72	4
UHS-055	55	70	9				
UHS-055	55	70	12				

# UHS (UN/UNS)

# PISTON & ROD SEAL

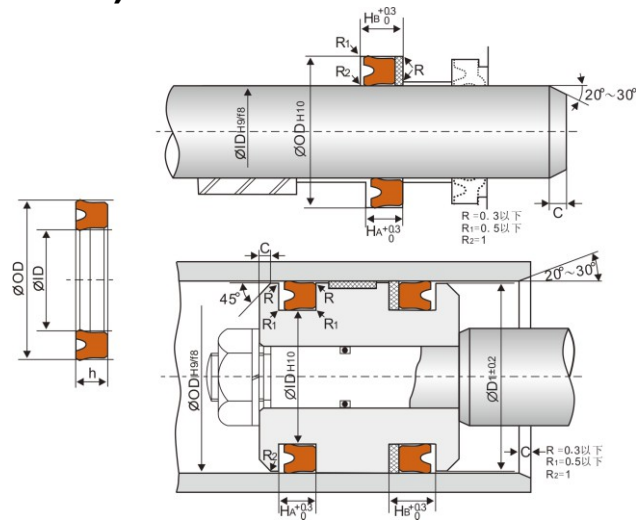

APPLICATION	
MATERIAL	PU
TEMP.	-35°C~100°C
PRESSURE	400kgf/cm <sup>2</sup>
SPEED	1m/s

ITEM	ID	OD	h	HA	HB	D1	C
* UHS-055	55	71	12	13	16	70	4
* UHS-055	55	75	12	13	16	74	4
* UHS-055	55	80	15	16	19	79	4
* UHS-056	56	72	12	13	16	71	4
* UHS-056	56	76	12	13	16	75	4
* UHS-058	58	78	12	13	16	77	4
UHS-060	60	75	10				
* UHS-060	60	71	7	8	11	70	4
UHS-060	60	80	12	13	16	79	4
* UHS-062	62	82	12	13	16	81	4
UHS-063	63	83	12	13	16	82	4
UHS-065	65	80	12				
UHS-065	65	85	12	13	16	84	5
* UHS-067	67	87	12	13	16	86	5
UHS-070	70	85	9				
UHS-070	70	85	12				
UHS-070	70	90	12	13	16	89	5
* UHS-071	71	91	12	13	16	90	5
UHS-075	75	85	12				
UHS-075	75	90	12				
UHS-075	75	95	12	13	16	94	5
UHS-080	80	90	8				
UHS-080	80	90	12				
UHS-080	80	95	12				
UHS-080	80	100	12	13	16	98	5
* UHS-080	80	100	15	16	19	98	5
UHS-085	85	95	12				
UHS-085	85	100	12				
* UHS-085	85	105	12	13	16	103	5
UHS-090	90	100	12				
* UHS-090	90	110	12	13	16	108	5
* UHS-092	92	112	12	13	16	110	5

# UHS (UN/UNS) PISTON & ROD SEAL

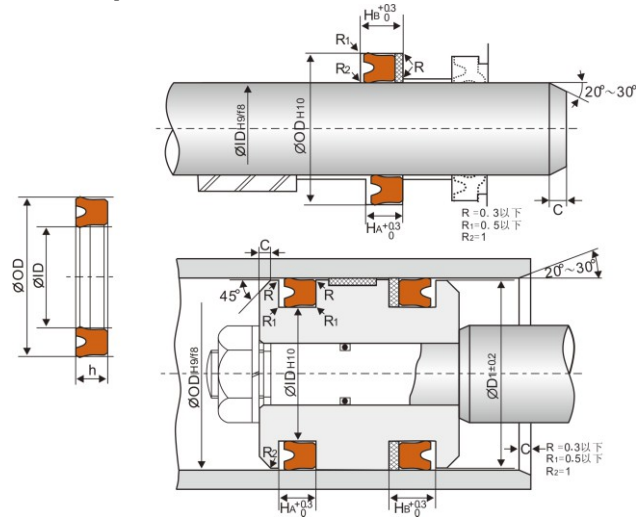

APPLICATION	
MATERIAL	PU
TEMP.	-35°C~100°C
PRESSURE	400kgf/cm <sup>2</sup>
SPEED	1m/s

ITEM	ID	OD	h	HA	HB	D1	C
UHS-095	95	115	12	13	16	113	5
* UHS-095	95	120	15	16	19	118	5
UHS-100	100	110	12				
UHS-100	100	120	12	13	16	118	5
UHS-105	105	125	15	17	20	123	5
* UHS-106	106	126	15	17	20	124	5
* UHS-100	100	125	15	17	20	123	5
UHS-110	110	120	12				
UHS-110	110	125	12				
UHS-110	110	130	15	17	20	128	5
* UHS-112	112	132	15	17	20	130	5
* UHS-115	115	135	15	17	20	133	5
* UHS-118	118	138	15	17	20	136	5
UHS-120	120	130	12				
UHS-120	120	140	15	17	20	138	5
UHS-130	130	140	12				
UHS-130	130	150	15				
* UHS-132	132	152	15	17	20	150	6.5
* UHS-135	135	150	15				
* UHS-135	135	155	15	17	20	153	6.5
UHS-140	140	150	12				
UHS-140	140	160	12				
* UHS-140	140	160	15	17	20	158	6.5
* UHS-140	140	165	15	17	20	163	6.5
* UHS-145	145	165	15	17	20	163	6.5
UHS-150	150	160	12				
UHS-150	150	170	15	17	20	168	6.5
* UHS-150	150	175	15	17	20	173	6.5
* UHS-155	155	180	15	17	21	178	6.5
UHS-160	160	180	15				
* UHS-160	160	185	15	17	21	183	6.5
* UHS-165	165	190	15	17	21	188	6.5

# UHS (UN/UNS) PISTON & ROD SEAL

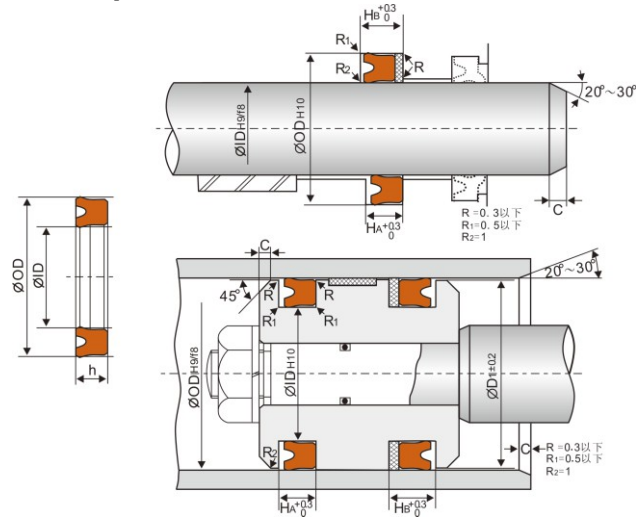

APPLICATION	
MATERIAL	PU
TEMP.	-35°C~100°C
PRESSURE	400kgf/cm <sup>2</sup>
SPEED	1m/s

ITEM	ID	OD	h	HA	HB	D1	C
UHS-170	170	190	15				
UHS-170	170	195	15	17	21	193	6.5
* UHS-175	175	200	15	17	21	198	6.5
UHS-180	180	205	15	17	21	203	6.5
UHS-185	185	210	15	17	21	208	6.5
* UHS-190	190	215	15	17	21	213	6.5
* UHS-199	199	224	15	17	21	222	6.5
* UHS-200	200	225	15	17	21	223	6.5
* UHS-200	200	225	18	20	24	203	6.5
* UHS-205	205	235	18	20	24	233	6.5
UHS-210	210	235	18	20	24	233	6.5
* UHS-212	212	237	18	20	24	235	6.5
* UHS-220	220	245	18	20	24	243	6.5
UHS-224	224	249	18	20	24	247	6.5
* UHS-225	225	250	18	20	24	248	6.5
UHS-230	230	250	15				
* UHS-230	230	254	18	20	24	252	6.5
* UHS-230	230	255	18	20	24	253	6.5
* UHS-236	236	261	18	20	24	259	6.5
* UHS-240	240	265	18	20	24	263	6.5
* UHS-250	250	275	18	20	24	273	6.5
* UHS-260	260	290	18	20	24	288	8
* UHS-265	265	295	18	20	24	293	8
* UHS-270	270	300	18	20	24	298	8
* UHS-280	280	310	18	20	24	308	8
* UHS-290	290	320	18	20	24	318	8
* UHS-300	300	330	18	20	24	328	8