

# UP



UP

The seal type Aston Seals UP is a high performance all purpose lipseal suitable for both rod and piston.

The UP profile assures a good reaction against shock pressure peaks and low friction in all conditions.

The material used to produce this seal is a polyurethane compound that ensures excellent properties on wear-resistance, extended service life and resistance against extrusion.

- Suitable for both rod and piston
- Economical solution
- Excellent wear-resistance

- Extended service life
- High resistance against extrusion
- Good temperature resistance
- Easy installation without expensive auxiliaries

## MATERIAL

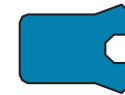

Type	Designation	Hardness
Polyurethane	SEALPUR 93	93 °ShA

## FIELD OF APPLICATION

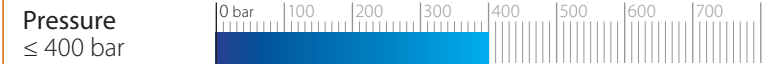

**Fluids** Hydraulic oils (mineral oil based)  
For other fluids contact our technical department

## SURFACE ROUGHNESS

Dynamic surface	Ra ≤ 0.3 µm	Rt ≤ 2.5 µm
Static surface	Ra ≤ 1.6 µm	Rt ≤ 6.3 µm

## GAP DIMENSION "g"

The largest gap dimension appearing in operation on the non-pressurised side:

50 bar	1.20 mm	300 bar	0.25 mm
100 bar	0.80 mm	400 bar	0.17 mm
200 bar	0.40 mm		

## LEAD-IN CHAMFERS

d	Smin
less 100	5 mm
100÷200	7 mm
over 200	10 mm

To avoid damaging the sealing lips during installation, housing must have rounded chamfers. Sharp edges and burrs within the installation area of the seal must be removed.

The above data are maximum values, they may be maintained for short periods and can not be used at the same time simultaneously.

# UP

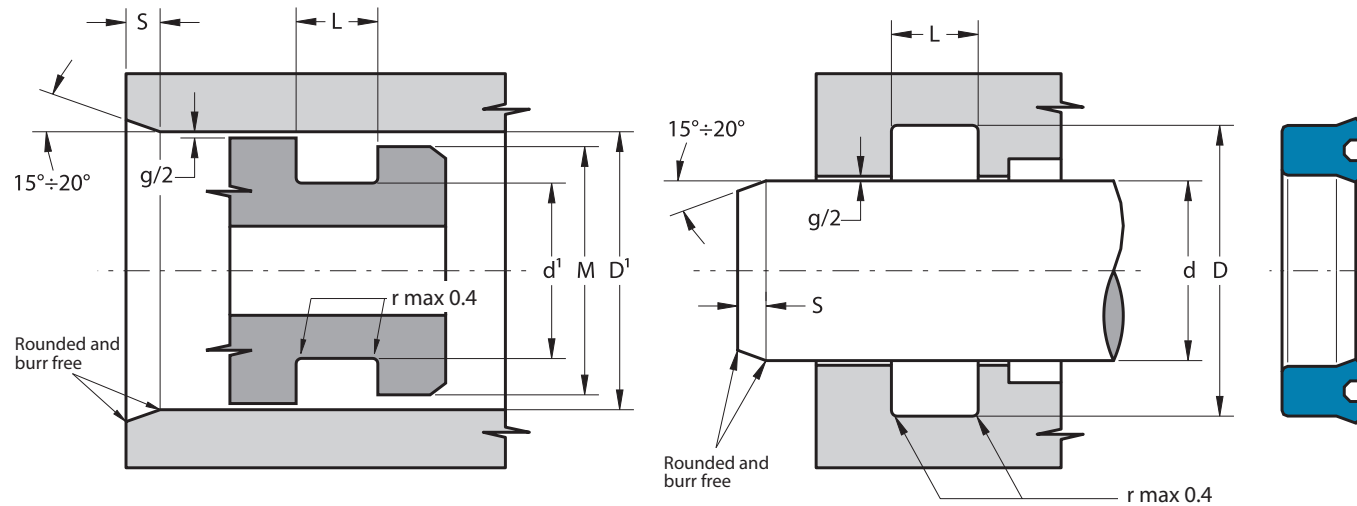

Part.	$d_{f7}^{d1 H8}$	$D_{H10}^{D1 H10}$	$L_{+0.25}$	M
UP 3 8 4	3	8	4.5	5
UP 3 9 4.5	3	9	5.0	5
UP 4 10 4	4	10	4.5	6
UP 4 10 4.5	4	10	5.0	6
UP 4.5 11 5	4.5	11	5.5	6.5
UP 5 12 4.5	5	12	5.0	7
UP 5 12 5	5	12	5.5	7
UP 5 12 6	5	12	7.0	7
UP 5 17 9	5	17	10.0	11
UP 6 12 4	6	12	4.5	8
UP 6 12 5.2	6	12	5.7	8
UP 6 12 5.5	6	12	6.0	8
UP 6 12 6	6	12	7.0	8
UP 6 12 8	6	12	9.0	8
UP 6 12.7 6	6	12.7	7.0	8
UP 6 15 8	6	15	9.0	9
UP 6.35 11.11 5	6.35	11.11	5.5	8.5
UP 7 14 3.5	7	14	4.2	9
UP 7 15 7	7	15	8.0	9
UP 8 12 2.4	8	12	3.5	10
UP 8 14 6	8	14	7.0	10
UP 8 15 5.8	8	15	6.3	10
UP 8 15 8	8	15	9.0	10
UP 8 16 4	8	16	4.5	10

Part.	$d_{f7}^{d1 H8}$	$D_{H10}^{D1 H10}$	$L_{+0.25}$	M
UP 8 16 5.8	8	16	6.3	10
UP 8 18 9	8	18	10.0	11
UP 8.4 16 5.8	8.4	16	6.3	10
UP 10 16 4	10	16	4.5	12
UP 10 16 5.6	10	16	6.2	12
UP 10 16 6	10	16	7.0	12
UP 10 18 5	10	18	6.0	12
UP 10 18 6	10	18	7.0	12
UP 10 18 8	10	18	9.0	12
UP 10 20 8	10	20	9.0	12
UP 10 22 8	10	22	9.0	13
UP 12 18 4.5	12	18	5.0	14
UP 12 18 5	12	18	5.5	14
UP 12 18 6	12	18	7.0	14
UP 12 20 8	12	20	9.0	14
UP 12 22 5	12	22	6.0	15
UP 12 22 7	12	22	8.0	15
UP 12 22 8	12	22	9.0	15
UP 12 24 8	12	24	9.0	15
UP 13 19 4	13	19	4.5	14.5
UP 14 20 4.8	14	20	5.3	16
UP 14 22 6	14	22	7.0	16
UP 14 24 8	14	24	9.0	16
UP 14 27 7	14	27	8.0	16

Part.	$d_{f7}^{d1 H8}$	$D_{H10}^{D1 H10}$	$L_{+0.25}$	M
UP 15 21.5 4.5	15	21.5	5.0	17
UP 15 25 8	15	25	9.0	18
UP 15 25 10	15	25	11.0	18
UP 15.85 22.3 5	15.85	22.3	6.0	18
UP 16 22 4	16	22	4.5	18
UP 16 22 5	16	22	5.5	18
UP 16 22 5.5	16	22	6.0	18
UP 16 24 5	16	24	6.0	18
UP 16 24 8	16	24	9.0	18
UP 16 24 9	16	24	10.0	18
UP 16 26 5	16	26	6.0	19
UP 16 26 8	16	26	9.0	19
UP 16 28 6	16	28	7.0	19
UP 16 28 9	16	28	10.0	19
UP 16 32 8	16	32	9.0	20
UP 17 23 4	17	23	4.5	19
UP 17 25 4	17	25	4.5	19
UP 17 25 6	17	25	7.0	19
UP 17 25 10	17	25	11.0	19
UP 17 27 6.5	17	27	7.6	19
UP 18 25 5	18	25	5.5	20
UP 18 26 6.5	18	26	7.5	20
UP 18 26 7.5	18	26	8.5	20
UP 18 26 8	18	26	9.0	20

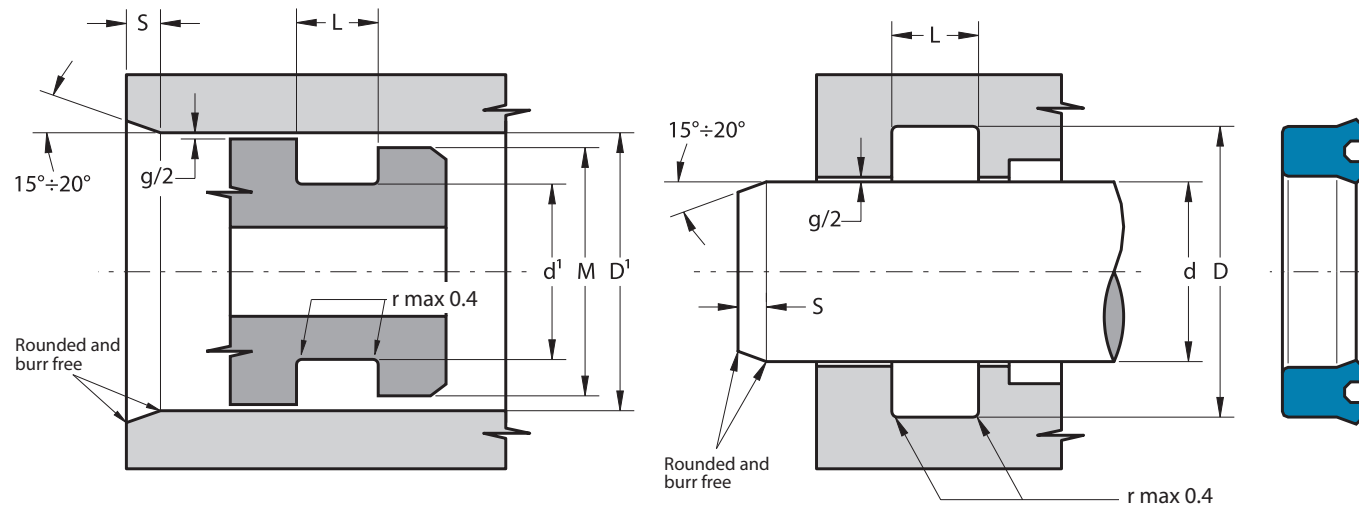

Part.	d <sup>1 f8</sup> d <sub>f7</sub>	D <sup>1 H10</sup> D <sub>H10</sub>	L <sup>+0.25</sup>	M
UP 18 26 8.5	18	26	9.5	20
UP 18 28 8	18	28	9.0	21
UP 18 30 8	18	30	9.0	21
UP 19 25 6	19	25	7.0	21
UP 20 26 3.3	20	26	3.8	22
UP 20 26 5	20	26	5.5	22
UP 20 26 6.5	20	26	7.5	22
UP 20 28 4	20	28	4.5	22
UP 20 28 5	20	28	5.5	22
UP 20 28 5.7	20	28	6.2	22
UP 20 28 7	20	28	8.0	22
UP 20 28 8	20	28	9.0	22
UP 20 29 5	20	29	5.5	22
UP 20 30 7	20	30	8.0	23
UP 20 30 8	20	30	9.0	23
UP 20 30 10	20	30	11.0	23
UP 20 32 7.5	20	32	8.5	23
UP 20 35 9	20	35	10.0	24
UP 20 40 10	20	40	11.0	24
UP 20 40 12	20	40	13.0	24
UP 20.5 26.5 3.5	20.5	26.5	4.0	22.5
UP 20.5 26.5 7	20.5	26.5	8.0	22.5
UP 22 27 2.6	22	27	3.0	24
UP 22 28 8	22	28	9.0	24

Part.	d <sup>1 f8</sup> d <sub>f7</sub>	D <sup>1 H10</sup> D <sub>H10</sub>	L <sup>+0.25</sup>	M
UP 22 30 6	22	30	7.0	24
UP 22 32 8	22	32	9.0	25
UP 22 32 10	22	32	11.0	25
UP 22 35 10	22	35	11.0	25
UP 22 40 10	22	40	11.0	25
UP 24 32 4	24	32	4.5	26
UP 24 32 6	24	32	7.0	26
UP 24 32 7	24	32	8.0	26
UP 24 34 5	24	34	5.5	27
UP 25 33 5	25	33	5.5	27
UP 25 33 6	25	33	7.0	27
UP 25 33 8	25	33	9.0	27
UP 25 35 5	25	35	5.5	28
UP 25 35 8	25	35	9.0	28
UP 25 35 10	25	35	11.0	28
UP 25 38 8	25	38	9.0	28
UP 25 38 10	25	38	11.0	28
UP 25 40 7	25	40	8.0	28
UP 25 40 10	25	40	11.0	28
UP 26 34 4	26	34	4.5	28
UP 27 36.5 6.8	27	36.5	7.8	30
UP 28 35 4.7	28	35	5.5	30
UP 28 35.5 5	28	35.5	5.5	30
UP 28 36 6.5	28	36	7.5	30

Part.	d <sup>1 f8</sup> d <sub>f7</sub>	D <sup>1 H10</sup> D <sub>H10</sub>	L <sup>+0.25</sup>	M
UP 28 38 7	28	38	8.0	31
UP 28 38 8	28	38	9.0	31
UP 28 38 10	28	38	11.0	31
UP 28 40 6.35	28	40	7.35	31
UP 28 40 10	28	40	11.0	31
UP 28 50 10	28	50	11.0	33
UP 30 36 4	30	36	4.5	32
UP 30 37 6	30	37	7.0	32
UP 30 38 4	30	38	4.5	32
UP 30 38 5.8	30	38	6.3	32
UP 30 38 6	30	38	6.5	32
UP 30 38 7	30	38	8.0	32
UP 30 40 5	30	40	5.5	33
UP 30 40 6	30	40	7.0	33
UP 30 40 9	30	40	10.0	32.5
UP 30 40 10	30	40	11.0	33
UP 30 42 9	30	42	10.0	33
UP 30 42 10	30	42	11.0	33
UP 30 45 10	30	45	11.0	34
UP 30 50 10	30	50	11.0	34
UP 30 50 12	30	50	13.0	34
UP 32 40 5.5	32	40	6.0	34
UP 32 40 8	32	40	9.0	34
UP 32 42 10	32	42	11.0	35

# UP

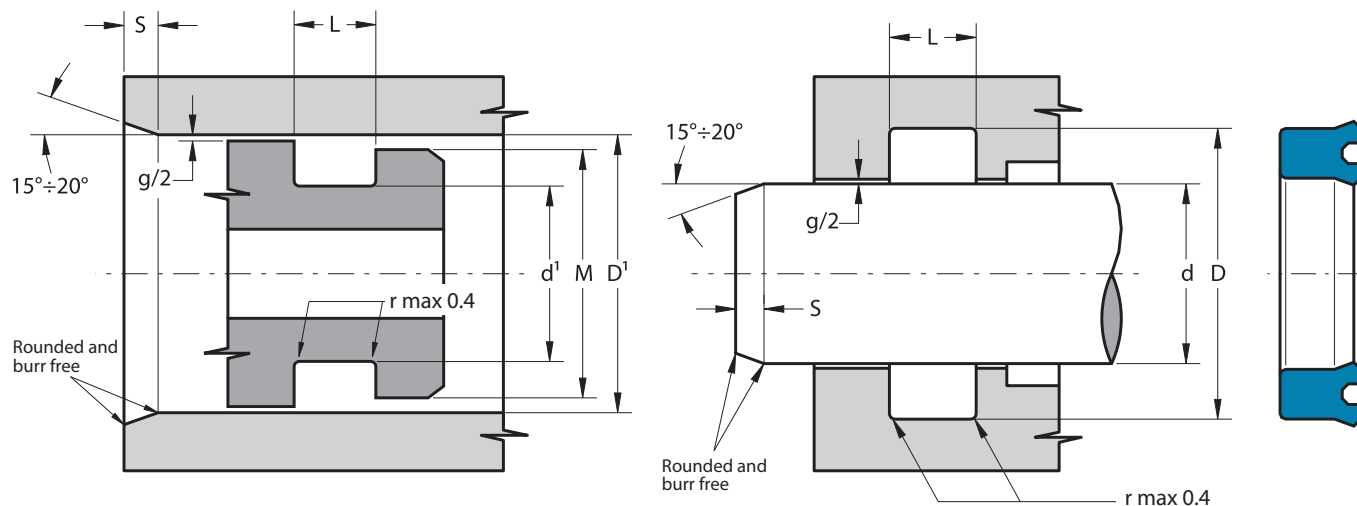

Part.	$d_{f7}^{1 f8}$	$D_{H10}^{1 H10}$	$L_{+0.25}$	M
UP 32 45 10	32	45	11.0	35
UP 34 45 7	34	45	8.0	37
UP 34 45 9	34	45	10.0	37
UP 35 43 6	35	43	7.0	37
UP 35 45 5	35	45	5.5	38
UP 35 45 6	35	45	7.0	38
UP 35 45 7	35	45	8.0	38
UP 35 45 8	35	45	9.0	38
UP 35 45 10	35	45	11.0	38
UP 35 48 10	35	48	11.0	38
UP 35 50 9	35	50	10.0	39
UP 35 50 10	35	50	11.0	39
UP 35 55 10	35	55	11.0	39
UP 35 55 12	35	55	13.0	39
UP 36 46 7	36	46	8.0	39
UP 36 48 8	36	48	9.0	39
UP 38 45 5	38	45	5.5	40
UP 38 46 6.5	38	46	7.5	40
UP 38 50 9	38	50	10.0	41
UP 38 55 10	38	55	11.0	41
UP 38 58 10	38	58	11.0	42
UP 40 48 5.8	40	48	6.3	42
UP 40 48 8	40	48	9.0	42
UP 40 50 5	40	50	5.5	43

Part.	$d_{f7}^{1 f8}$	$D_{H10}^{1 H10}$	$L_{+0.25}$	M
UP 40 50 6	40	50	7.0	43
UP 40 50 6.5	40	50	7.5	43
UP 40 50 8	40	50	9.0	43
UP 40 50 9	40	50	10.0	43
UP 40 50 10	40	50	11.0	43
UP 40 55 10	40	55	11.0	44
UP 40 60 10	40	60	11.0	45
UP 40 60 13	40	60	14.0	45
UP 42 50 6	42	50	7.0	44
UP 42 50 8	42	50	9.0	44
UP 42 52 9	42	52	10.0	45
UP 42 62 12	42	62	13.0	47
UP 45 53 6.5	45	53	7.5	48
UP 45 55 6	45	55	7.0	48
UP 45 55 6.5	45	55	7.5	48
UP 45 55 10	45	55	11.0	48
UP 45 56 7	45	56	8.0	48
UP 45 60 10	45	60	11.0	49
UP 45 63 10	45	63	11.0	49
UP 45 65 10	45	65	11.0	50
UP 45 65 12	45	65	13.0	50
UP 48 58 10	48	58	11.0	51
UP 50 60 5	50	60	5.5	53
UP 50 60 6	50	60	7.0	53

Part.	$d_{f7}^{1 f8}$	$D_{H10}^{1 H10}$	$L_{+0.25}$	M
UP 50 60 7	50	60	8.0	53
UP 50 60 10	50	60	11.0	53
UP 50 60 11	50	60	12.0	53
UP 50 62 9	50	62	10.0	53
UP 50 63 6	50	63	7.0	54
UP 50 63 9	50	63	10.0	54
UP 50 65 7	50	65	8.0	54
UP 50 65 10	50	65	11.0	54
UP 50 70 10	50	70	11.0	55
UP 50 70 12	50	70	13.0	55
UP 52 62 12	52	62	13.0	55
UP 53 63 6.5	53	63	7.5	56
UP 55 65 6	55	65	7.0	58
UP 55 65 10	55	65	11.0	58
UP 55 65 12	55	65	13.0	58
UP 55 70 12	55	70	13.0	59
UP 55 75 12	55	75	13.0	60
UP 55 80 12	55	80	13.0	60
UP 56 66 5	56	66	5.5	59
UP 56 66 6	56	66	7.0	59
UP 59.6 70 5.2	59.6	70	5.7	63
UP 60 70 5	60	70	5.5	63
UP 60 70 6	60	70	7.0	63
UP 60 70 8	60	70	9.0	63

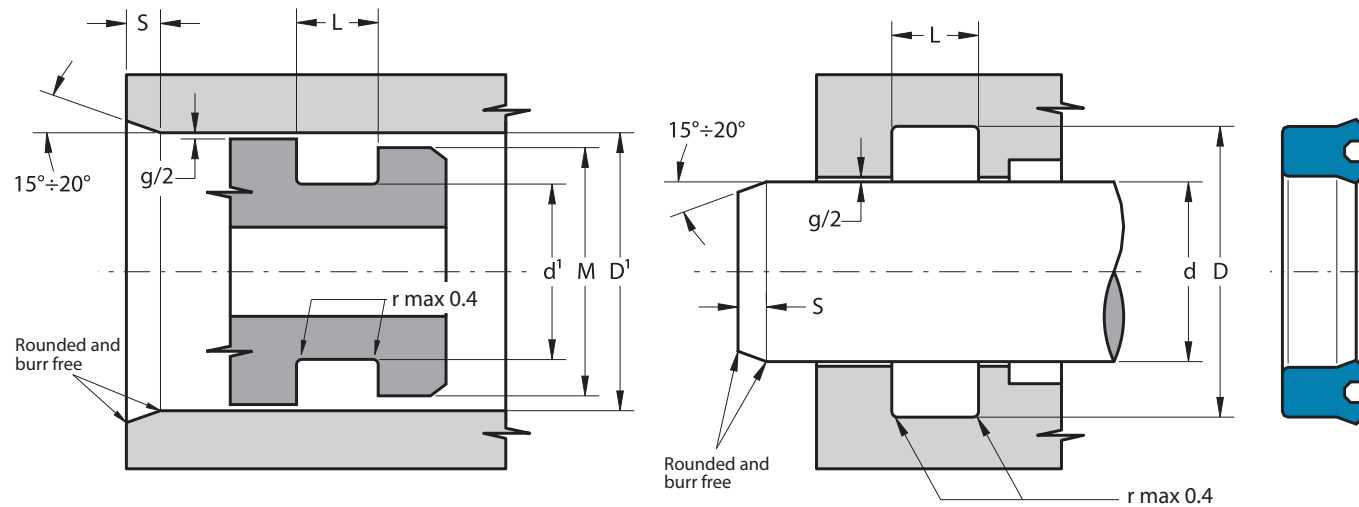

Part.	d <sup>1 f8</sup> d <sub>f7</sub>	D <sup>1 H10</sup> D <sub>H10</sub>	L <sup>+0.25</sup>	M
UP 60 70 10	60	70	11.0	63
UP 60 70 12	60	70	13.0	63
UP 60 71 7	60	71	8.0	63
UP 60 72 9.52	60	72	10.5	63
UP 60 75 10	60	75	11.0	64
UP 60 75 11.4	60	75	12.4	64
UP 60 75 12	60	75	13.0	64
UP 60 80 10	60	80	11.0	65
UP 60 80 12	60	80	13.0	65
UP 60 80 18	60	80	19.0	65
UP 63 73 6	63	73	7.0	66
UP 63 75 10	63	75	11.0	66
UP 63 78 10	63	78	11.0	67
UP 65 75 6	65	75	7.0	68
UP 65 75 12	65	75	13.0	68
UP 65 80 10	65	80	11.0	69
UP 65 80 11	65	80	12.0	69
UP 65 80 12	65	80	13.0	69
UP 65 85 12	65	85	13.0	70
UP 67 77 10	67	77	11.0	70
UP 67.3 80 6.5	67.3	80	7.5	71
UP 68 92.4 14	68	92.4	15.0	74
UP 70 75 3.5	70	75	4.1	72
UP 70 80 5	70	80	6.0	73

Part.	d <sup>1 f8</sup> d <sub>f7</sub>	D <sup>1 H10</sup> D <sub>H10</sub>	L <sup>+0.25</sup>	M
UP 70 80 6	70	80	7.0	73
UP 70 80 8	70	80	9.0	73
UP 70 80 10	70	80	11.0	73
UP 70 80 12	70	80	13.0	73
UP 70 85 11	70	85	12.0	74
UP 70 85 12	70	85	13.0	74
UP 70 90 12	70	90	13.0	75
UP 70 90 18	70	90	19.0	75
UP 75 85 6	75	85	7.0	78
UP 75 85 12	75	85	13.0	78
UP 75 90 7.5	75	90	8.5	79
UP 75 90 10	75	90	11.0	79
UP 75 90 12	75	90	13.0	79
UP 75 95 10	75	95	11.0	80
UP 75 95 12	75	95	13.0	80
UP 75 95 13.5	75	95	14.5	80
UP 75 95 14.5	75	95	15.5	80
UP 77.5 87.5 10	77.5	87.5	11.0	81
UP 80 90 5	80	90	6.0	83
UP 80 90 6	80	90	7.0	83
UP 80 90 8	80	90	9.0	83
UP 80 90 10	80	90	11.0	83
UP 80 90 12	80	90	13.0	83
UP 80 95 12	80	95	13.0	84

Part.	d <sup>1 f8</sup> d <sub>f7</sub>	D <sup>1 H10</sup> D <sub>H10</sub>	L <sup>+0.25</sup>	M
UP 80 100 9.5	80	100	10.5	85
UP 80 100 10	80	100	11.0	85
UP 80 100 12	80	100	13.0	85
UP 80 100 15.9	80	100	16.9	85
UP 85 95 8.5	85	95	9.5	88
UP 85 95 12	85	95	13.0	88
UP 85 100 9	85	100	10.0	89
UP 85 100 10	85	100	11.0	89
UP 85 100 12	85	100	13.0	89
UP 85 105 12	85	105	13.0	90
UP 90 100 7	90	100	8.0	93
UP 90 100 8	90	100	9.0	93
UP 90 100 12	90	100	13.0	93
UP 90 103 10	90	103	11.0	94
UP 90 105 12	90	105	13.0	94
UP 90 110 12	90	110	13.0	95
UP 90 115 12	90	115	13.0	95
UP 90 115 15	90	115	16.0	95
UP 95 110 9	95	110	10.0	99
UP 95 110 12	95	110	13.0	99
UP 95 115 12	95	115	13.0	100
UP 100 115 9	100	115	10.0	104
UP 100 115 12	100	115	13.0	104
UP 100 120 12	100	120	13.0	105

# UP

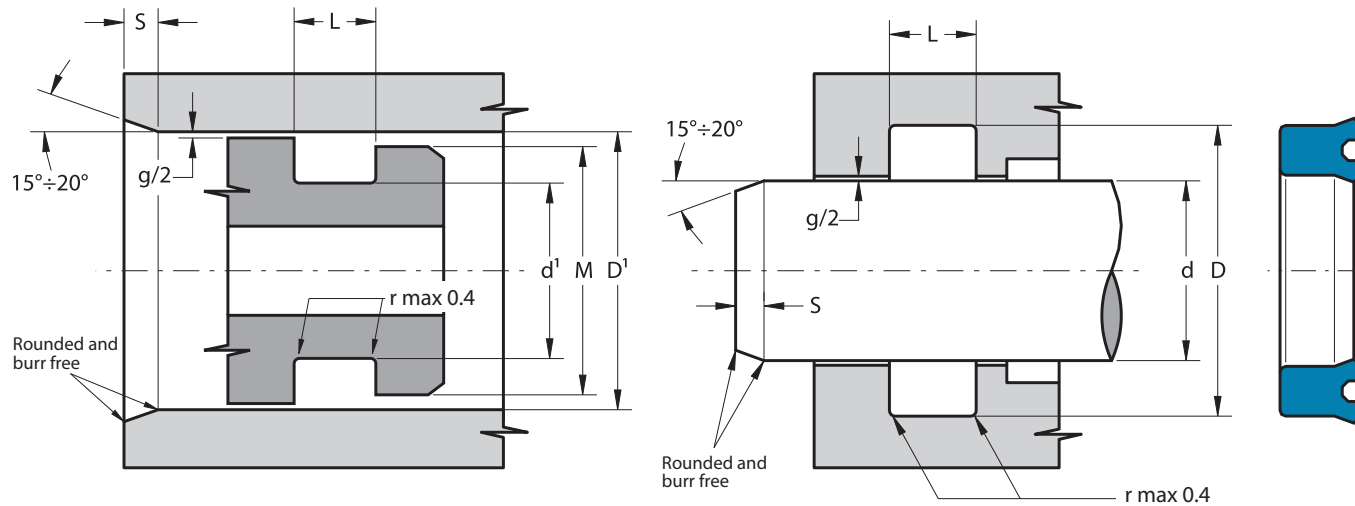

Part.	$d^{1\text{ H8}}$ $d^{f7}$	$D^{1\text{ H10}}$ $D^{H10}$	$L_{+0.25}$	M
UP 100 125 12	100	125	13.0	105
UP 100 125 15	100	125	16.0	105
UP 105 120 8	105	120	9.0	109
UP 105 120 11	105	120	12.0	109
UP 105 120 15	105	120	16.0	109
UP 105 125 12	105	125	13.0	110
UP 105 125 15	105	125	16.0	110
UP 109 125 11	109	125	12.0	114
UP 110 125 9	110	125	10.0	114
UP 110 125 12	110	125	13.0	114
UP 110 125 15	110	125	16.0	114
UP 110 130 15	110	130	16.0	115
UP 115 135 15	115	135	16.0	118
UP 120 140 15	120	140	16.0	125
UP 120 145 19.05	120	145	20.05	126
UP 125 140 9	125	140	10.0	129
UP 125 140 11	125	140	12.0	129
UP 125 140 15	125	140	16.0	129
UP 125 145 15	125	145	16.0	130
UP 128 140 12	128	140	13.0	131

Part.	$d^{1\text{ H8}}$ $d^{f7}$	$D^{1\text{ H10}}$ $D^{H10}$	$L_{+0.25}$	M
UP 130 145 12	130	145	13.0	134
UP 130 150 15	130	150	16.0	135
UP 140 155 9	140	155	10.0	144
UP 140 160 12	140	160	13.0	145
UP 140 160 15	140	160	16.0	145
UP 145 165 15	145	165	16.0	150
UP 150 170 15	150	170	16.0	155
UP 160 175 12	160	175	13.0	164
UP 160 180 15	160	180	16.0	165
UP 170 190 12	170	190	13.0	175
UP 170 190 15	170	190	16.0	175
UP 175 200 15	175	200	16.0	180
UP 180 200 15	180	200	16.0	185
UP 180 205 18	180	205	19.0	186
UP 190 210 15	190	210	16.0	195
UP 200 220 12	200	220	13.0	205
UP 200 220 15	200	220	16.0	205
UP 200 225 18	200	225	19.0	206
UP 220 250 18	220	250	19.0	225

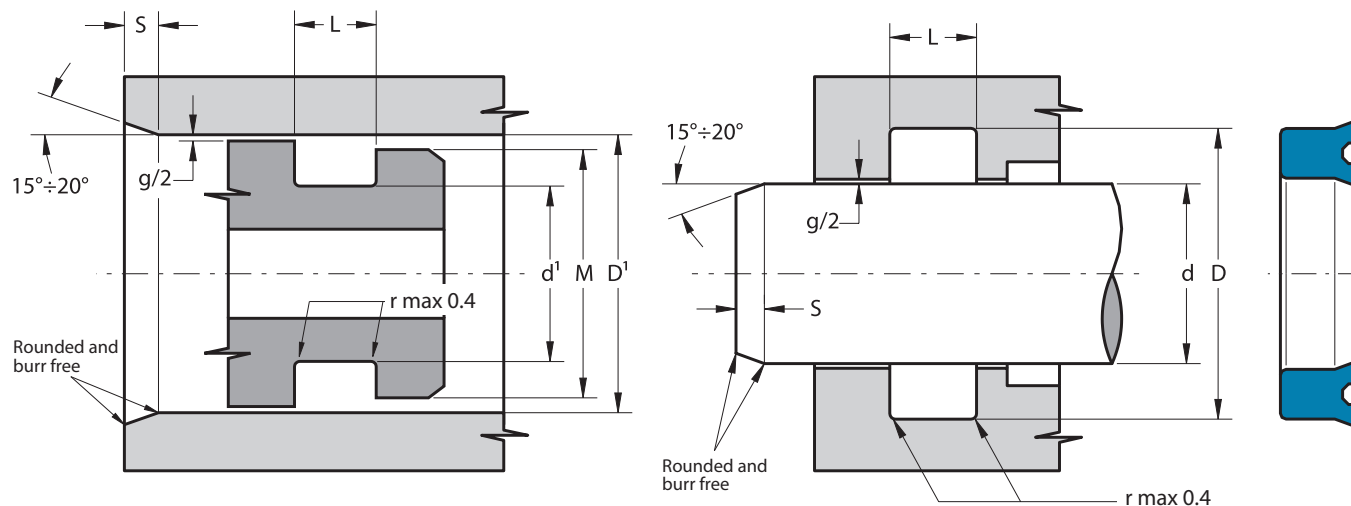

Part.	$d^1_{f8}$ $d_{f7}$	$D^1_{H10}$ $D_{H10}$	$L_{+0.25}$	M
-------	------------------------	--------------------------	-------------	---

Inch sizes

UP 0750 1000 0250	19.05	25.4	7.35	21.2
UP 1000 1250 0250	25.40	31.75	7.35	27.0
UP 1000 1375 0312	25.4	34.92	8.9	27.8
UP 1250 1500 0250	31.75	38.10	7.35	34.0
UP 1250 1625 0312	31.75	41.28	8.90	34.1
UP 1375 1750 0312	34.92	44.45	8.90	37.3
UP 1500 1875 0312	38.10	47.62	8.90	40.5
UP 1500 2000 0250	38.10	50.80	7.35	41.9
UP 1500 2000 0375	38.10	50.80	10.50	41.3
UP 1625 2000 0375	41.28	50.80	10.50	43.3
UP 1750 2125 0375	44.45	53.97	10.50	46.8
UP 2000 2500 0250	50.80	63.50	7.35	54.6
UP 2000 2500 0375	50.80	63.50	10.50	54.6
UP 2000 2625 0562	50.80	66.68	14.78	55.5
UP 2000 2750 0500	50.80	69.85	13.70	55.6
UP 2125 2625 0406	53.97	66.68	11.00	58.0
UP 2250 2625 0375	57.15	66.68	10.50	60.3
UP 2250 2750 0375	57.15	69.85	10.50	60.4
UP 2125 2500 0375	59.97	63.50	10.50	58.7
UP 2500 3000 0375	63.50	76.20	10.50	67.6
UP 2500 3125 0500	63.50	79.37	13.70	67.5

Part.	$d^1_{f8}$ $d_{f7}$	$D^1_{H10}$ $D_{H10}$	$L_{+0.25}$	M
-------	------------------------	--------------------------	-------------	---

UP 2500 3250 0620	63.50	82.55	16.75	68.5
UP 2625 3000 0187	66.68	76.20	5.25	69.9
UP 2750 3250 0375	69.85	82.55	10.50	74.0
UP 2750 3500 0500	69.85	88.90	13.70	74.6
UP 3000 3500 0375	76.20	88.90	10.50	80.0
UP 3000 3625 0562	76.20	92.08	14.78	80.9
UP 3000 3750 0620	76.20	95.25	16.75	81.0
UP 3250 4000 0625	82.55	101.6	16.90	92.1
UP 3500 3875 0375	88.90	98.43	10.50	92.0
UP 3500 4000 0375	88.90	101.60	10.50	93.0
UP 3500 4250 0620	88.90	107.95	16.75	94.0
UP 3875 4250 0187	98.43	107.95	5.25	101.6
UP 4000 4500 0375	101.60	114.30	10.50	105.7
UP 4375 5000 0562	111.13	127.00	15.27	115.1
UP 5250 6000 0620	133.36	152.40	16.75	138.0
UP 6000 7000 0750	152.40	177.80	20.00	158.6
UP 6250 7000 0620	158.75	177.80	16.75	163.7
UP 6500 7500 0765	165.10	190.50	20.40	170.0
UP 7000 8000 0750	177.80	203.20	20.10	184.0
UP 8000 9000 0750	203.20	228.60	20.00	209.4

