

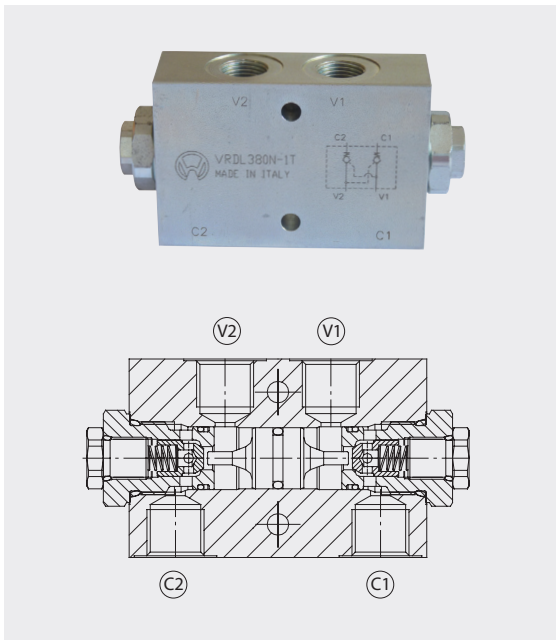

VRDL Valvole di blocco pilotate a doppio effetto

Double acting pilot check valves



Dati tecnici

Technical data

Olio idraulico Mineral oil	ISO 6743/4 DIN 51524
Viscosità fluido Fluid viscosity	10-500 mm ² /s 45 to 2000 ssu (6 to 420 cSt)
Classe di contaminazione max con filtro Max contamination index with filter	ISO 4406:1999 Classe 19/17/14
Temperatura del fluido Fluid temperature	-20°C +80°C -4°F + 176°F
Temperatura ambiente Ambient temperature	-20°C +50°C -4°F + 122°F

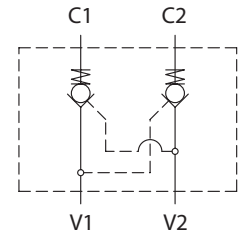

È indispensabile l'utilizzo di un filtro (filtrazione consigliata 15 micron) per proteggere la valvola

It is necessary a filter use to protect the valve (advised filtration 15 micron)

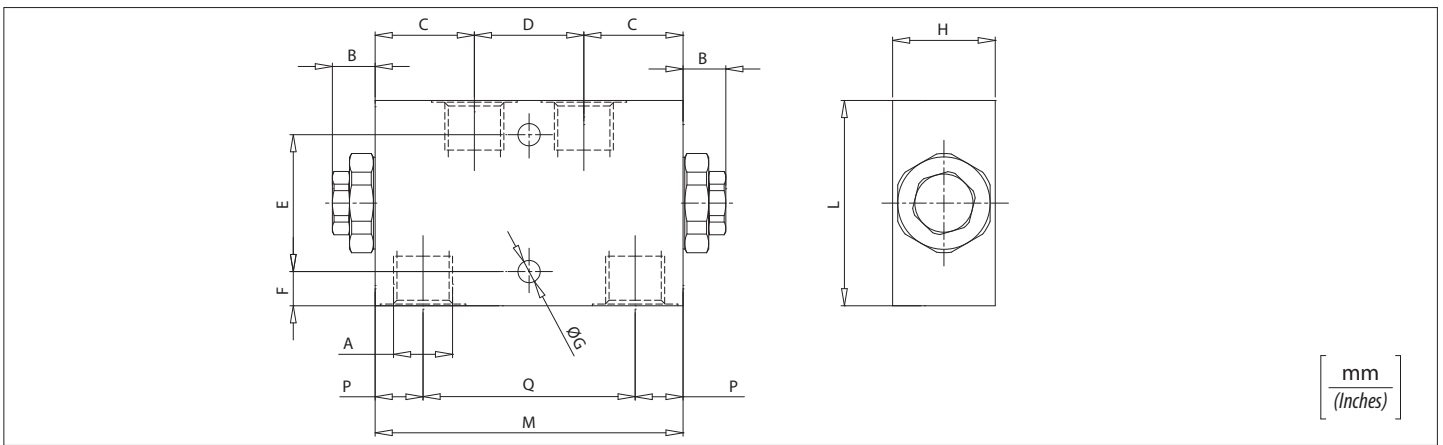

mm
(Inches)

Perdite di carico *Pressure drops*

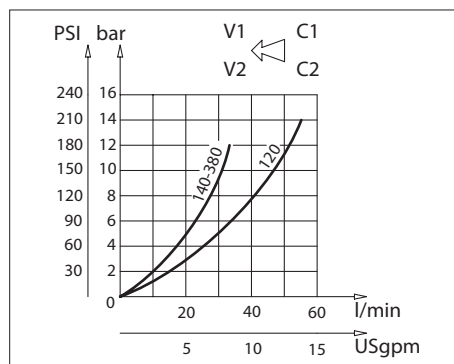
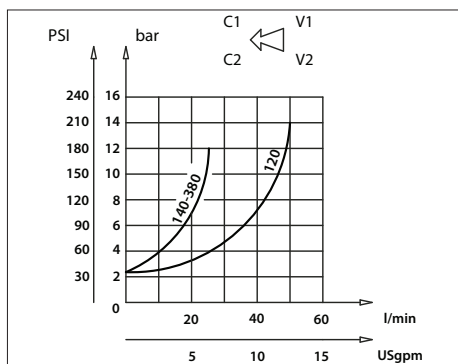

Codice ordinazione / *Ordering code*

VRDL - X

X

Dimensione / *Size*

140N

BSPP 1/4

380N

BSPP 3/8

120N

BSPP 1/2

Caratteristiche tecniche / *Technical performances*

Codice Code	A	Portata max Max Flow l/min-USgpm	Pressione Max Max pressure bar/PSI	B	C	D	E	F	G	H	L	M	P	Q	Peso approssimativo Approx weight Kg / lb	Rapporto di pilotaggio Pilot ratio
VRDL140N	BSPP 1/4	35 (9)	350 (5000)	12,5 (0.49)	29 (1.14)	32 (1.25)	40 (1.57)	10 (0.39)	6,5 (0.25)	30 (1.18)	60 (2.36)	90 (3.54)	14 (0.55)	62 (2.44)	1,2 (2.6)	1:7
VRDL380N	BSPP 3/8															
VRDL120N	BSPP 1/2	50 (13)		14,5 (0.57)	38 (1.49)	34 (1.33)		15 (0.59)	8,5 (0.33)	35 (1.37)	70 (2.75)	110 (4.33)	20,5 (0.80)	69 (2.71)	1,9 (4.2)	