



# RCF FOOT PEDAL LOWER PORTS

Hydraulic remote control RCF belongs to the wide range of Hydrocontrol S.p.A. This Pedal is characterized by reduced overall dimensions and several configurations. RCF works according to the principle of direct-acting pressure reducing valves. In rest position, the foot pedal is held in neutral by return spring; inlet port P is closed and ports are connected to tank port T. P, T and users ports are under the body, opposite to the pedal.



### TECHNICAL SPECIFICATIONS

Max pressure: **100 bar**

Oil capacity: **12 l/min**

Weight: **4,1 Kg**

### APPLICATIONS

Mini-excavators

### DIMENSIONS

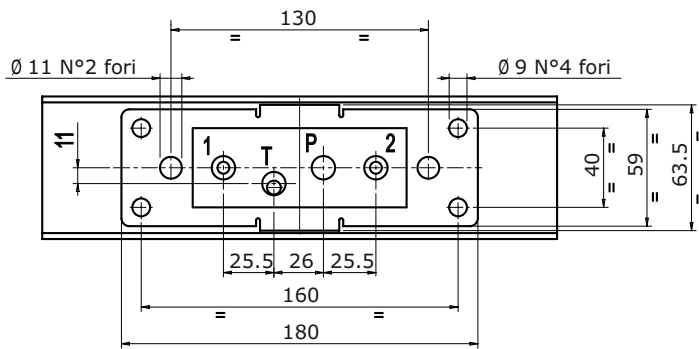

HYDRAULIC SCHEMA

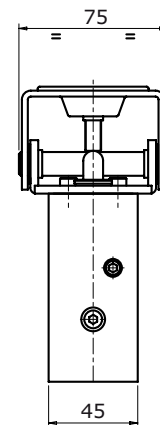
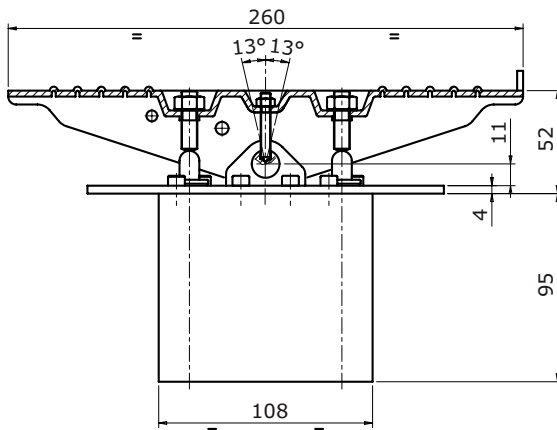
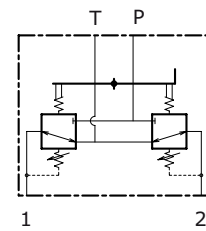



FOOT PEDAL LOWER PORTS **RCF**

ORDER EXAMPLE = RCF: 01S - A01 - MA - RA G02

- RCF product type \_\_\_\_\_
- 1 CONTROL CLASSIFICATION:** \_\_\_\_\_
- 01S** control type
- 2 METERING CURVE:** \_\_\_\_\_
- A01** curve type
- 3 RETURN SPRING:** \_\_\_\_\_
- MA** return spring type
- 4 BODY ARRANGEMENT:** \_\_\_\_\_
- RA** body specification
- G02** body thread

Ordering row 2 and 3, must be repeated for each port  
 complete sample: **RCF: 01S A01 MA A01 MA RA G02**

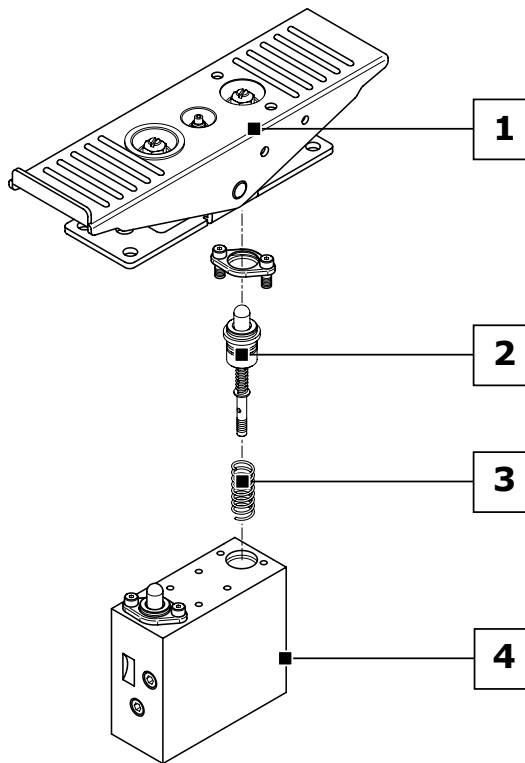

<b>1</b>	<b>CONTROL CLASSIFICATION:</b> (page 40)
<b>01S</b>	Foot pedal with return spring in neutral
<b>02S</b>	Foot pedal with prearranged handle and return spring in neutral
<b>03S</b>	Foot pedal with adjustable angle and prearranged handle and return spring in neutral
<b>04S</b>	Foot pedal with adjustable angle with return spring in neutral
<b>2</b>	<b>METERING CURVE:</b> (page 70)
<b>A01</b>	Linear metering curve with step
<b>B01</b>	Linear metering curve without step
<b>C01</b>	Broken line metering curve with step
<b>D01</b>	Broken line metering curve without step

<b>3</b>	<b>RETURN SPRING:</b> (page 79)
<b>MA</b>	Preload 25 N - End stroke load 48 N
<b>MB</b>	Preload 14 N - End stroke load 27 N
<b>MC</b>	Preload 73 N - End stroke load 135 N
<b>MD</b>	Preload 89 N - End stroke load 169 N
<b>4</b>	<b>BODY ARRANGEMENT:</b> (page 41)
<b>RA G02</b>	Standard Body (G 1/4 ports)
<b>RA U02</b>	Standard Body (9/16"-18 UNF ports)



RCF FOOT PEDAL LOWER PORTS

CONTROL KIT CLASSIFICATION

All controls installed on the foot pedal RCF are interchangeable. The controls shown correspond to standard configurations; for different applications contact our Commercial Dept.

Code	Configuration	Schema	Description
01S			Foot pedal with return spring in neutral
02S			Foot pedal with prearranged handle and return spring in neutral
03S			Foot pedal with adjustable angle and prearranged handle and return spring in neutral
04S			Foot pedal with adjustable angle with return spring in neutral



**BODY ARRANGEMENT**

The foot pedal RCF has only one setting body, the only variable is represented by a different thread.

Code	Configuration	Schema	Description
RA G02			Standard body with ports G 1/4
RA U02			Standard body with ports 9/16" - 18 UNF