



	01	02	03	04
Codice ordinazione Ordering code	DRF10			

01	Valvola Divisore/riunificatore di flusso (Flow Divider/Combiner valves)	DRF10
02	Campo di portata in ingresso (l/min) Inlet flow range (USgpm)	2-5 (0.5-1.3)
		3-10 (0.8-2.6)
		7-20 (1.8-5.2)
		15-40 (3.9-10.4)
03	Connessione P (Port P)	BSPP 3/8
		BSPP 1/2
04	Connessione U1/U2 (Port U1/U2)	BSPP 3/8
		BSPP 1/2

Dati tecnici - Technical data

Olio idraulico/Mineral oil	ISO 6743/4 (DIN 51524)	
Viscosità olio/Oil viscosity	15-250 mm ² /s (15 to 250 cSt)	
Classe di contaminazione max con filtro Max contamination index with filter	ISO 4406:1999 Classe 19/17/14	
Temperatura dell'olio/Oil temperature	-20°C +80°C	-4°F + 176°F
Temperatura ambiente/Ambient temperature	-20°C +50°C	-4°F + 122°F
È indispensabile l'utilizzo di un filtro per proteggere la valvola (filtrazione consigliata 15 µm) It is necessary a filter use to protect the valve (advised filtration 15 µm)		

Schema idraulico - Hydraulic circuit

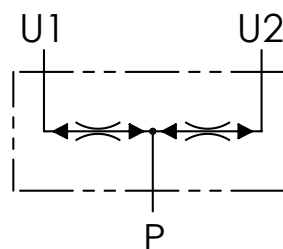

Performances

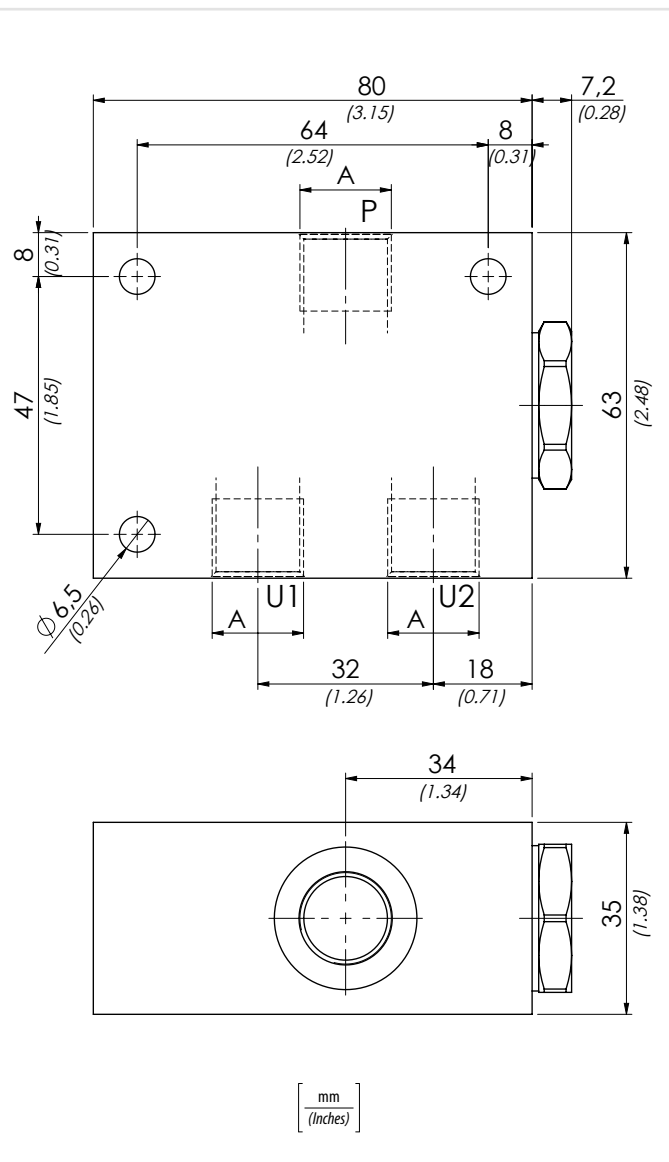
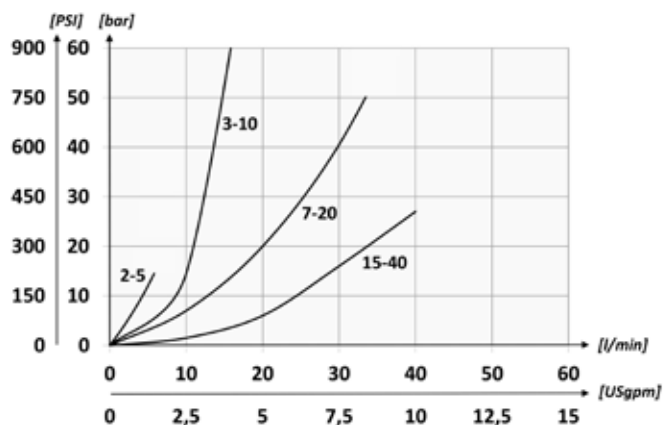

Caratteristiche tecniche - Technical characteristics

Tipo Type	Portata max (l/min) Max flow (USgpm)	Pressione max (bar) Max pressure (PSI)	Peso approssimativo (kg) Approx weight (lb)
DRF10	40 (10.6)	250 (3625)	0,52 (1.14)

[mm]
[Inches]