



## MP16M type pressure relief valve - 2 way

- Pilot operated
- Spool type
- SAE16 cavities

Technical specifications and diagrams are measured with mineral oil of 46 cSt viscosity at 40°C (104°F) temperature.

### MP16M

Nominal flow		400 l/min (105.67 US gpm)
Max. pressure		350 bar (5100 psi)
Oil leakage	80% of max. pressure setting	100 cm <sup>3</sup> /min (6.102 in <sup>3</sup> /min)
Fluid		mineral based oil
Viscosity		12-400 cSt
Max level of contamination		20/18/14 ISO4406
Fluid temperature	with NBR seals with FPM seals	from -20°C (-4°F) to 80°C (176°F) from -20°C (-4°F) to 100°C (212°F)
Environmental temp. for working conditions		from -20°C (-4°F) to 50°C (122°F)
Cavity		SAE 16/2
Weight		0.490 kg (1.080 lb)

NOTE - For different conditions, please contact Walvoil Sales Dpt.

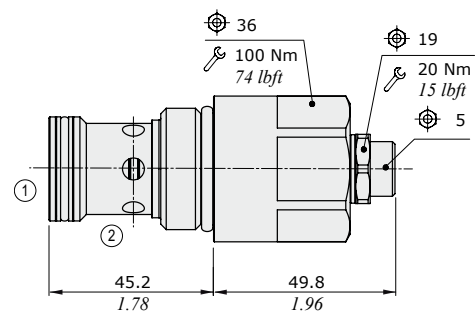
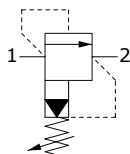

## Ordering codes and description composition

### MP16M/OY2B

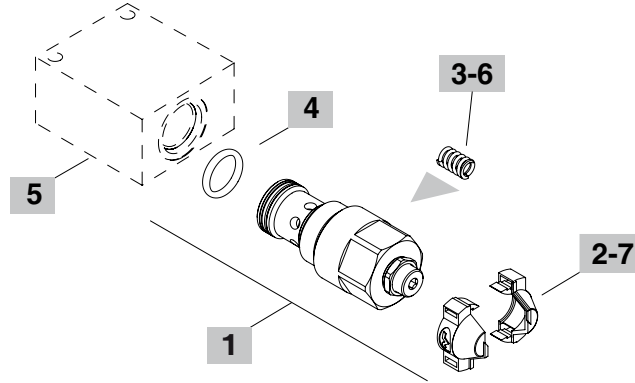
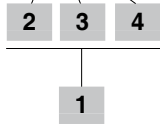

1 Cartridges			5 Valve body		
TYPE	CODE	DESCRIPTION	TYPE	CODE	DESCRIPTION
<b>SAE cavity 16/2</b>			<b>SAE 16/2-G 1</b>		
MP16M/OY1B	OMP16002017	Pressure range 1	3CC1620F210		Steel body for cavity 16 valve, G 1 std thread
MP16M/OY2B	OMP16002013	Pressure range 2	Note: aluminium body can stand up to 210 bar (3050 psi)		
MP16M/OY3B	OMP16002014	Pressure range 3	For other bodies or different threading see from page 215		

2 Adjustments			6 Springs		
TYPE	DESCRIPTION		TYPE	CODE	DESCRIPTION
Y	With screw		1	3ML1081400	Pressure range 1 - white band
X	Valve set with antitampering cap (part code: see point 7)		2	3ML1081401	Pressure range 2 - no band
			3	3ML1081402	Pressure range 3 - red band

3 Pressure range			7 Accessories		
TYPE	DESCRIPTION		TYPE	CODE	DESCRIPTION
1	Pressure range 15÷50 bar (217.5÷725 psi)		-	4COP126300	Antitampering cap (x2)
2	Pressure range 50÷220 bar (725÷3190 psi)				
3	Pressure range 150÷350 bar (2175÷5100 psi)				

4 Seals		
TYPE	DESCRIPTION	
B	<b>NBR (Buna)</b> o-ring seals, std configuration	
V	<b>FPM (Viton)</b> o-ring seals, contact Sales Dept.	

## Rating diagrams

**MP16M pressure vs. flow (range 1)**  
Std. setting at 5 l/min (1.32 US gpm)

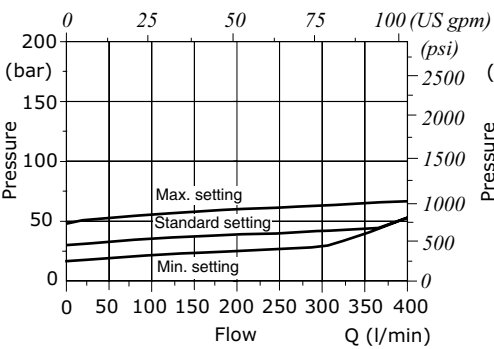

**MP16M pressure vs. flow (range 2)**  
Std. setting at 5 l/min (1.32 US gpm)

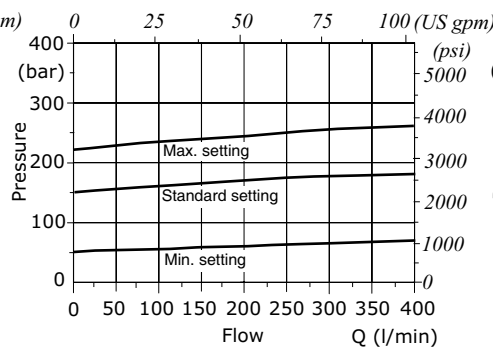

**MP16M pressure vs. flow (range 3)**  
Std. setting at 5 l/min (1.32 US gpm)

