Technical Features

- › Valve is primary used in clutch control application typically in mobile transmissions
- › Excellent stability throughout flow range with rapid response to proportional current input change
- › Low hysteresis, accurate pressure control and low pressure drop through CFD optimized flow paths
- › Precise pressure control vs current and excellent repeatability
- › Integrated relief function for protection against pressure peaks
- › Solenoid electrical terminal AMP Junior Timer or Deutsch DT04-2P
- › 12 or 24 V DC coils
- › Compact design with reduced solenoid dimensions for production cost savings
- › High flow capacity and low coil power consumption
- › Optional mesh screen
- › In the standard version, the valve is zinc-coated for 240 h protection acc. to ISO 9227

Functional Description

A direct-operated, spool-type hydraulic pressure reducing valve in the form of a slip-in cartridge. Reduced pressure output is proportional to DC current input. This valve is intended for use as a pressure limiting device. Note: Consult factory for special OEM versions of this product.

Model Code	no mesh screen	with mesh screen
Symbol		

Technical Data

Valve size / Cartridge cavity		D20 / W3	
Max. operating pressure (port P)	bar (PSI)	50 (730)	
Max. reducing pressure (port A)	bar (PSI)	20 (290)	25 (363)
Max. flow rate P-A	l/min (GPM)	30 (7.9)	
Fluid temperature range (NBR)	°C (°F)	-30 ...90 (-22 ...194), +100 (212) short-time	
Fluid temperature range (FPM)	°C (°F)	-20 ...90 (-4 ...194), +100 (212) short-time	
Ambient temperature range	°C (°F)	-30 ...90 (-22 ...194), +100 (212) short-time	
Response time at 100% signal	ms	< 50	
Solenoid data			
Supply voltage	V	12 DC	24 DC
Max. current	A	1	1
Rated resistance at 20 °C (68 °F)	Ω	7.2±6.5%	11.2±6.5%
Duty cycle	%	100	
Optimal PWM frequency	Hz	100	
Quenching diode		BZW06-28B	BZW06-33B
Enclosure type acc. to EN 60529**		(acc.to terminal type) IP 67 / IP 69K	
Weight	kg (lbs)	0.4 (0.88)	
	Data Sheet	Type	
General information		GL_0060 Products and operating conditions	
Valve bodies	In-line mounted	SB_0018	SB-W3-*
Cavity details		SMT_0019	SB-W3-*
Spare parts		SP_8010	

**The indicated IP protection level is only reached with a properly mounted connector.

Dimensions in millimeters (inches)
Connector type

 E3, E4 - IP67
 AMP Junior Timer

 E12, E13 - IP67 / IP69K
 Deutsch DT04-2P

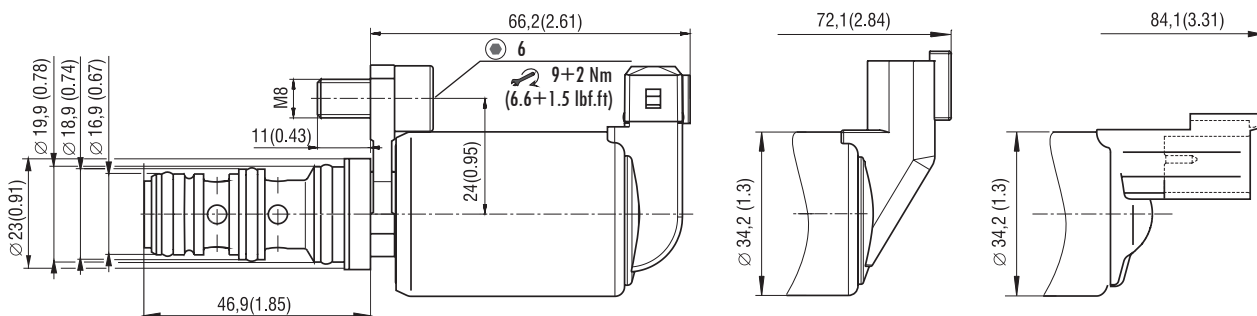
 E12A, E13A - IP67 / IP69K
 Deutsch DT04-2P

Characteristics measured at $v = 32 \text{ mm}^2/\text{s}$ (156 SUS)

Reduced pressure related to control signal

Port A, range 0 - 20 bar (290 PSI)
 Port A, range 0 - 25 bar (363 PSI)
 Port P, Inlet pressure 50 bar (730 PSI)
 $Q = 0 \text{ lpm}$ (GPM)

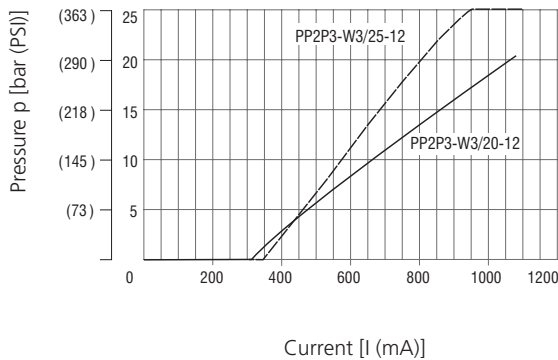

Pressure drop related to flow rate

A-T, Valve coil de-energized (relieving function)
 P-A, Valve coil energized (reducing function)

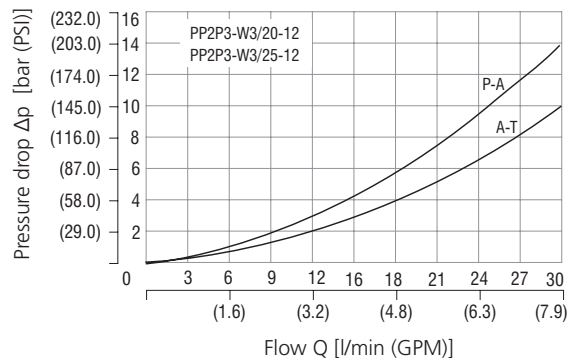

Reducing pressure related to flow rate

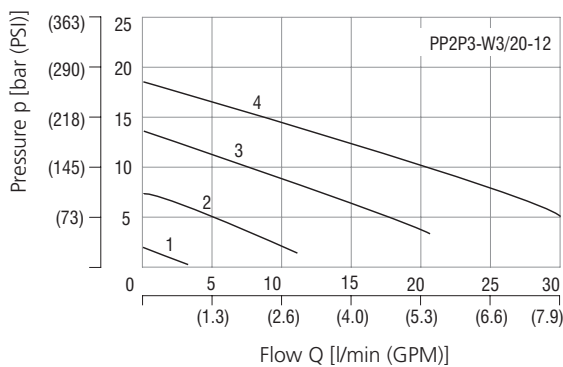

Reducing pressure related to flow rate

Reducing Function P - A

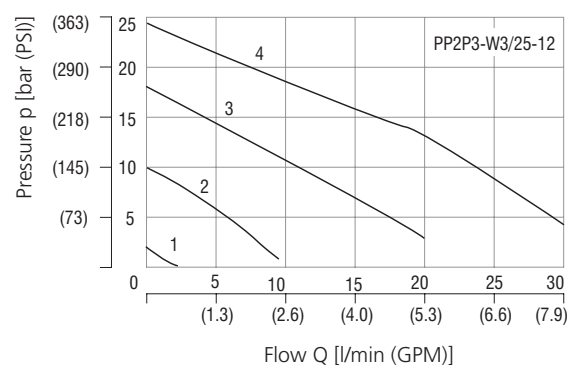

Control signal	
1	40 %
2	60 %
3	80 %
4	100 %

Ordering Code

PP2P3 - W3/ [] - [] [] [] - [] []

Proportional pressure control valve,
 reducing - relieving, direct-acting,
 slip-in style

Valve cavity
 D20 mm (0.79 in)

Max. reducing pressure
 20 bar (290 PSI) **20**
 25 bar (363 PSI) **25**

Supply voltage / max. current
 12 V DC / 1 A **12**
 24 V DC / 1 A **24**

Mesh screen
No designation without mesh screen
SP-125 port P, 125 microns

Surface treatment
A zinc-coated (ZnCr-3), ISO 9227 (240 h)
B zinc-coated (ZnNi), ISO 9227 (520 h)

Seals
No designation NBR
V FPM (Viton)

Connector
E3 AMP Junior Timer - radial direction (2 pins; male)
E4 E3 with quenching diode
E12 Deutsch DT04-2P - radial direction
E13 E12 with quenching diode
E12A Deutsch DT04-2P - axial direction
E13A E12A with quenching diode

Besides the shown, commonly used valve versions other special models are available.
 Contact our technical support for their identification, feasibility and operating limits.