

Proportional Pressure Control Valve, Relieving, Direct-Acting

SR1P2-A2

3/4-16 UNF • Q_{max} 1.5 l/min (0.40 GPM) • p_{max} 350 bar (5100 PSI)

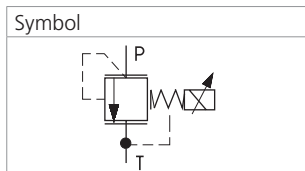
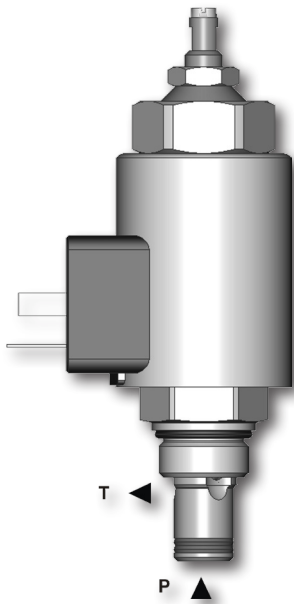

Technical Features

- › Increasing pressure output proportional with increasing DC current input
- › Low hysteresis, accurate pressure control
- › Wide pressure range up to 350 bar
- › Solenoid electrical terminal option acc. to EN 175301-803-A, AMP Junior Timer, or Deutsch DT04-2P
- › 12 or 24 V DC coils
- › Usable as pilot stage for SR4P2-B2 and SP4P2-B3 proportional valves
- › In the standard version, the valve is zinc-coated for 240 h protection acc. to ISO 9227

Functional Description

A direct operated proportional poppet pressure relief valve in the form of a screw-in cartridge. The valve is designed for continuous regulation of system pressure. It is used mostly as a pilot stage. To set the minimum cracking pressure use the adjusting screw (s=5) which incorporates also the air bleed screw. Back pressure on port T becomes additive to the pressure setting of the valve. Air bleeding is necessary for the correct function of the valve. Installation: When possible, the valve should be mounted below the reservoir oil level. This will keep oil in the actuator at all times, preventing instability caused by air enclosures. If this is not possible, mount the valve for best results vertically downward with proper air bleeding.

Technical Data

Valve size / Cartridge cavity		3/4-16 UNF-2A / A2	
Max. operating pressure (port P)	bar (PSI)	350 (5080)	
Max. operating pressure (port T)	bar (PSI)	100 (1450)	
Max. flow	l/min (GPM)	1.5 (0.40)	
Fluid temperature range (NBR)	°C (°F)	-30 ... +120 (-22 ... 248)	
Fluid temperature range (FPM)	°C (°F)	-20 ... +120 (-4 ... 248)	
Ambient temperature range	°C (°F)	-30 ... +80 (-22 ... 176)	
Hysteresis	%	< 5	
Solenoid data			
Supply voltage	V	12 DC	24 DC
Max. current	A	1	0.6
Rated resistance at 20 °C (68 °F)	Ω	6.5 ± 5 %	20.6 ± 5 %
Duty cycle	%	100	
Optimal PWM frequency	Hz	200	
Quenching diode		BZW06-19B	BZW06-33B
Enclosure type acc. to EN 60529**		IP65 / IP67 / IP69K	
Weight with solenoid	kg (lbs)	0.44 (0.97)	
	Data Sheet	Type	
General information		GI_0060	
Coil types		C_8007	
Valve bodies	In-line mounted	SB_0018	SB-A2*
	Sandwich mounted	SB-04(06)_0028	SB-*A2*
Cavity details / Form tools		SMT_0019	
Spare Parts		SP_8010	

**The indicated IP protection level is only reached with a properly mounted connector.

Dimensions in millimeters (inches)

Connector type

E1, E2 - IP65
EN 175301-803-A

E3, E4 - IP67
AMP Junior Timer
- radial

E3A, E4A - IP67
AMP Junior Timer
- axial

E12A, E13A
- IP67 / IP69K
Deutsch DT04-2P

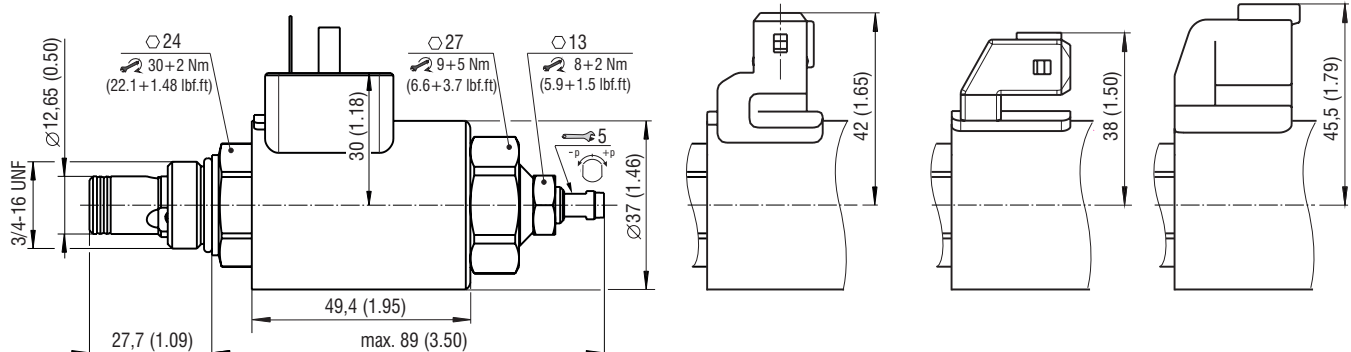

Characteristics measured at $v = 32 \text{ mm}^2/\text{s}$ (156 SUS)

Relief pressure related to control signal

$Q=0.2 \text{ l/min}$ (0.05 GPM), pressure in port T=0 bar, PWM 160Hz

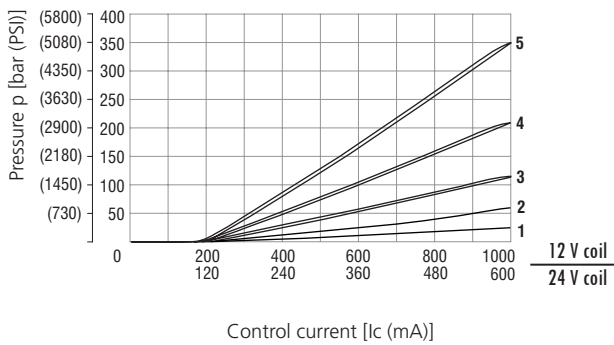

Pressure range	3	6	12	21	35
	1	2	3	4	5

Relief pressure related to flow rate

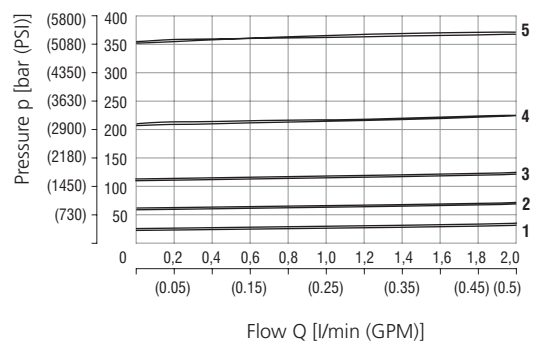

Pressure range	3	6	12	21	35
	1	2	3	4	5

Pressure drop related to flow rate

0% of control current, P-T direction

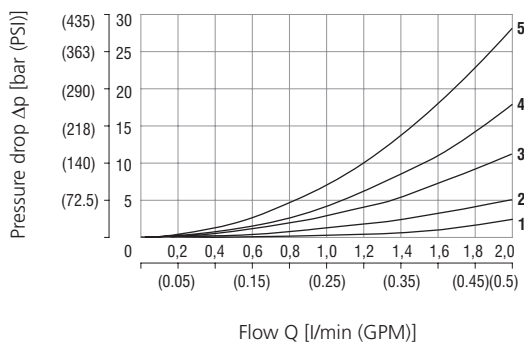

Pressure range	3	6	12	21	35
	1	2	3	4	5



Attention:
The proportional pressure relief valve is not mechanically protected and it does not perform the relief valve function.

Ordering Code

SR1P2 - A2 / H [] - [] [] [] - []

Proportional pressure control valve, relieving, direct-acting

Valve cavity
3/4-16UNF

Model
High performance

Max. regulated pressure

up to 30 bar (435 PSI)	3
up to 60 bar (870 PSI)	6
up to 120 bar (1740 PSI)	12
up to 210 bar (3046 PSI)	21
up to 350 bar (5076 PSI)	35

Supply voltage / max. current

12 V DC / 1 A	12
24 V DC / 0.6 A	24

Surface treatment

A	zinc-coated (ZnCr-3), ISO 9227 (240 h)
B	zinc-coated (ZnNi), ISO 9227 (520 h)

Seals

No designation	NBR
V	FPM (Viton)

Connector type

E1	EN 175301-803-A
E2	E1 with quenching diode
E3	AMP Junior Timer - radial direction (2 pins; male)
E4	E3 with quenching diode
E3A	AMP Junior Timer - axial direction (2 pins; male)
E4A	E3A with quenching diode
E12A	Deutsch DT04-2P - axial direction
E13A	E12A with quenching diode

For other solenoid terminals see data sheet No. 8007