



Type VPR/3/ET flow control pressure compensated valves

- 3 ways

Technical specifications and diagrams are measured with mineral oil of 46 cSt viscosity at 40°C (104°F) temperature.

		VPR/3/ET 38	VPR/3/ET 12	VPR/3/ET 34	VPR/3/ET 100	VPR/3/ET 114
Max. inlet flow	Line E	50 l/min (13.2 US gpm)	90 l/min (23.8 US gpm)	150 l/min (39.6 US gpm)	240 l/min (63.4 US gpm)	350 l/min (92.5 US gpm)
Max. regulated flow	Line C	30 l/min (7.9 US gpm)	50 l/min (13.2 US gpm)	90 l/min (23.8 US gpm)	150 l/min (39.6 US gpm)	250 l/min (66 US gpm)
Max. regulated flow "SB"		15 l/min (4.0 US gpm)	25 l/min (6.6 US gpm)	45 l/min (11.9 US gpm)	75 l/min (19.8 US gpm)	125 l/min (33 US gpm)
Max. pressure		Aluminium body = 210 bar (3050 psi) Steel body = 350 bar (5100 psi)				
Fluid		mineral based oil				
Viscosity		from 10 to 200 cSt				
Max. level of contamination		18/16/13 ISO4406				
Fluid temperature		with NBR seals from -20°C (-4°F) to 80°C (176°F)				
Environmental temperature for working conditions		from -40°C (-40°F) to 100°C (212°F)				
Weight	aluminium	1.07 kg (2.36 lb)	1.02 kg (2.25 lb)	2.22 kg (4.89 lb)	4.06 kg (8.95 lb)	4.49 kg (20.94 lb)
	steel	2.48 kg (5.47 lb)	2.43 kg (5.36 lb)	4.42 kg (9.74 lb)	8.49 kg (18.72 lb)	9.65 kg (21.27 lb)

NOTE - For different conditions, please contact Walvoil Sales Dpt.

*"SB" execution (sensibilized adjustment)

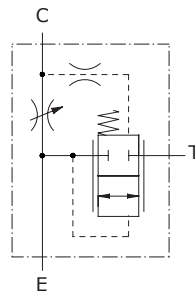

Dimensions

VPR/3/ET 38 - VPR/3/ET 12 - VPR/3/ET 34

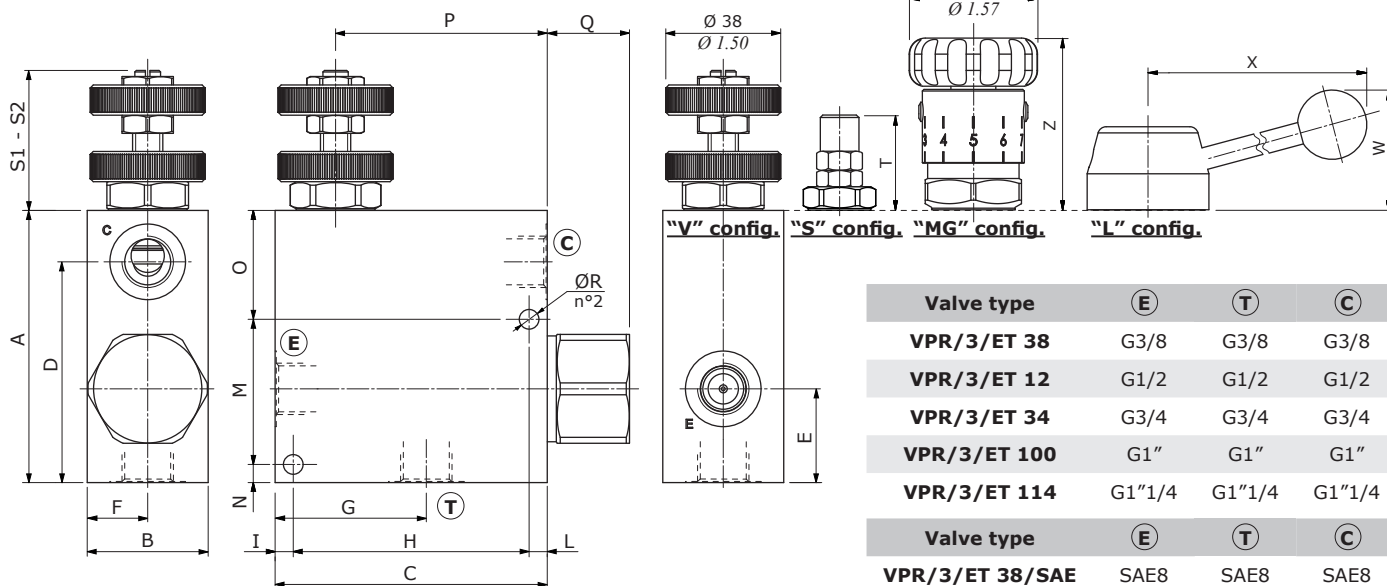

Valve type	Ⓔ	Ⓓ	Ⓒ
VPR/3/ET 38	G3/8	G3/8	G3/8
VPR/3/ET 12	G1/2	G1/2	G1/2
VPR/3/ET 34	G3/4	G3/4	G3/4
VPR/3/ET 100	G1"	G1"	G1"
VPR/3/ET 114	G1"1/4	G1"1/4	G1"1/4

Valve type	Ⓔ	Ⓓ	Ⓒ
VPR/3/ET 38/SAE	SAE8	SAE8	SAE8
VPR/3/ET 12/SAE	SAE10	SAE10	SAE10
VPR/3/ET 34/SAE	SAE12	SAE12	SAE12
VPR/3/ET 100/SAE	SAE16	SAE16	SAE16
VPR/3/ET 114/SAE	SAE20	SAE20	SAE20

VPR/3/ET 100 - VPR/3/ET 114

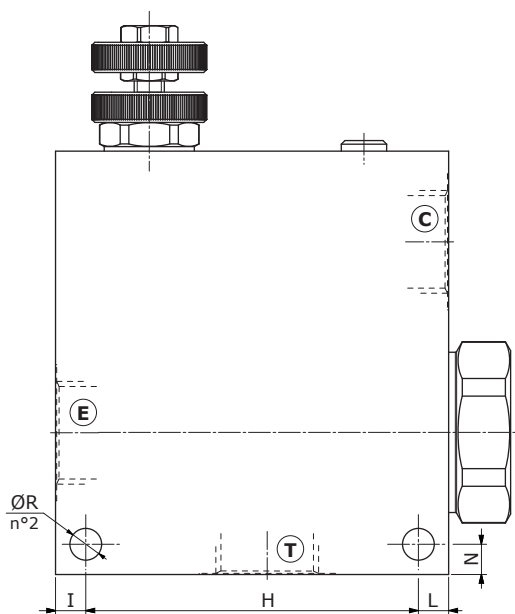

Dimensions are in mm-in

Valve type	A	B	C	D	E	F
VPR/3/ET 38	90-3.54	40-1.57	90-3.54	73-2.87	31-1.22	20-0.78
VPR/3/ET 38/SAE						
VPR/3/ET 12	90-3.54	40-1.57	90-3.54	73-2.87	31-1.22	20-0.78
VPR/3/ET 12/SAE						
VPR/3/ET 34	110-0.31	50-1.97	110-4.33	85-3.35	35-1.38	25-0.98
VPR/3/ET 34/SAE						
VPR/3/ET 100	140-5.51	Alum: 70-2.75 Steel: 65-2.56	130-5.11	110-4.33	47-1.85	Alum: 35-1.38 Steel: 32.5-1.38
VPR/3/ET 100/SAE						
VPR/3/ET 114	165-6.5	Alum: 70-2.75 Steel: 65-2.56	130-5.11	135-5.31	65-2.56	Alum: 35-1.38 Steel: 32.5-1.38
VPR/3/ET 114/SAE						

Valve type	G	H	I - L	M	N	O	P
VPR/3/ET 38	47.5-1.87	78-3.07	6-0.24	48-1.89	6-0.236	36-1.42	70-2.75
VPR/3/ET 38/SAE							
VPR/3/ET 12	47.5-1.87	78-3.07	6-0.24	48-1.89	6-0.236	36-1.42	70-2.75
VPR/3/ET 12/SAE							
VPR/3/ET 34	66-2.60	94-3.70	8-0.31	55.5-2.18	8-0.315	46.5-1.83	82-3.23
VPR/3/ET 34/SAE							
VPR/3/ET 100	70-2.75	110-4.33	10-0.39	-	10-0.394	-	99-3.90
VPR/3/ET 100/SAE							
VPR/3/ET 114	35-1.38	110-4.33	10-0.39	-	10-0.394	-	99-3.90
VPR/3/ET 114/SAE							

Valve type	Q	ØR	S1	S2*	T	W	X	Z
VPR/3/ET 38	27.2-1.07	6.5-0.25	46.3-1.82	52.6-2.07	38.5-1.51	47.6-1.87	101.3-3.99	53.3-2.10
VPR/3/ET 38/SAE								
VPR/3/ET 12	27.2-1.07	6.5-0.25	46.3-1.82	53.1-2.09	38.5-1.51	47.6-1.87	101.3-3.99	53.3-2.10
VPR/3/ET 12/SAE								
VPR/3/ET 34	34.5-1.36	8.5-0.33	41.5-1.73	50.5-1.99	38.5-1.51	50.1-1.97	103.6-4.08	56.5-2.22
VPR/3/ET 34/SAE								
VPR/3/ET 100	20.5-0.81	10.5-0.41	41.5-1.73	50.5-1.99	38.5-1.51	50.1-1.97	103.6-4.08	56.5-2.22
VPR/3/ET 100/SAE								
VPR/3/ET 114	20.5-0.81	10.5-0.41	52-2.05	-	41.5-1.63	50.5-1.99	107.3-4.22	56.5-2.22
VPR/3/ET 114/SAE								

Flow control valves

Flow control pressure compensated valves

VPR/3/ET

Ordering codes and description composition

Port size
VPR/3/ET 38/V
1

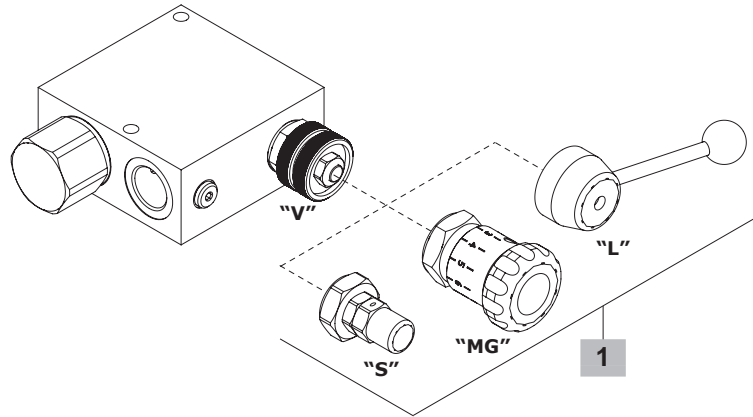

VPR/3/ET complete valves

Adjustment kit type "V" (handwheel)

TYPE	CODE	DESCRIPTION
VPR/3/ET 38/V	1620021100	Aluminium body, 3/8 ports
VPR/3/ET 12/V	1620031100	Aluminium body, 1/2 ports
VPR/3/ET 34/V	1620041100	Aluminium body, 3/4 ports
VPR/3/ET 100/V	1620051100	Aluminium body, 1" ports
VPR/3/ET 114/V	1620061100	Aluminium body, 1" 1/4 ports
VPR/3/ET 38/V/ac	1620022100	Steel body, 3/8 ports
VPR/3/ET 12/V/ac	1620032100	Steel body, 1/2 ports
VPR/3/ET 34/V/ac	1620042100	Steel body, 3/4 ports
VPR/3/ET 100/V/ac	1620052101	Steel body, 1" ports
VPR/3/ET 114/V/ac	1620062101	Steel body, 1" 1/4 ports
VPR/3/ET 38/V/SAE	1620021200	Aluminium body, SAE8 ports
VPR/3/ET 12/V/SAE	1620031200	Aluminium body, SAE10 ports
VPR/3/ET 34/V/SAE	1620041200	Aluminium body, SAE12 ports
VPR/3/ET 100/V/SAE	1620051200	Aluminium body, SAE16 ports
VPR/3/ET 114/V/SAE	1620061200	Aluminium body, SAE20 ports

Adjustment kit type "MG" (handknob)

VPR/3/ET 38/MG	1620021101	Aluminium body, 3/8 ports
VPR/3/ET 12/MG	1620031101	Aluminium body, 1/2 ports
VPR/3/ET 34/MG	1620041101	Aluminium body, 3/4 ports
VPR/3/ET 100/MG	1620051101	Aluminium body, 1" ports
VPR/3/ET 114/MG	1620061101	Aluminium body, 1" 1/4 ports

Adjustment kit type "L" (lever)

VPR/3/ET 38/L	1620021102	Aluminium body, 3/8 ports
VPR/3/ET 12/L	1620031102	Aluminium body, 1/2 ports
VPR/3/ET 34/L	1620041102	Aluminium body, 3/4 ports
VPR/3/ET 100/L	1620051102	Aluminium body, 1" ports
VPR/3/ET 114/L	1620061102	Aluminium body, 1" 1/4 ports
VPR/3/ET 38/L/SAE	1620021201	Aluminium body, SAE8 ports
VPR/3/ET 34/L/SAE	1620042200	Aluminium body, SAE12 ports

For other steel body configurations, SAE thread and configurations with FPM (Viton) seals, please contact our Sales Dpt.

1 Adjustment kit

TYPE	CODE	DESCRIPTION
For VPR/3/ET 38 valve		
V.SB	5KT6200200	"V" handwheel type in "SB" configuration (sensibilized adjustment)
V	5KT6130200	"V" handwheel type
MG	5KT6200202	"MG" handknob type
S	5KT6200211	"S" screw type
For VPR/3/ET 12 valve		
V.SB	5KT6130301	"V" handwheel type in "SB" configuration (sensibilized adjustment)
V	5KT6130200	"V" handwheel type
MG	5KT6200202	"MG" handknob type
S	5KT6200211	"S" screw type
For VPR/3/ET 34 and VPR/2/ET 100 valves		
V	5KT6130401	"V" handwheel type
MG	5KT6200400	"MG" handknob type
S	5KT6130404	"S" screw type
V.SB	5KT6130402	"V" handwheel type in "SB" configuration (sensibilized adjustment)
For VPR/3/ET 114 valve		
V	5KT6340603	"V" handwheel type
MG	5KT6200605	"MG" handknob type
S	5KT6200604	"S" screw type

Rating diagrams

VPR/3/ET 38 compensation diagram E-> C

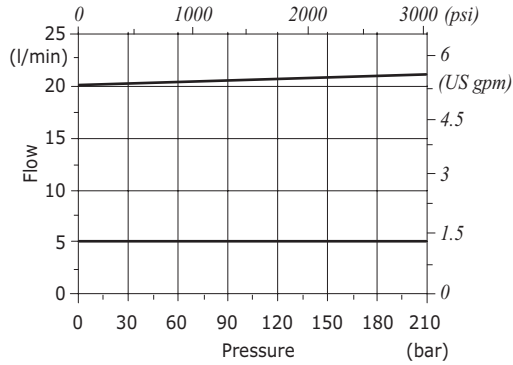

VPR/3/ET 12 compensation diagram E-> C

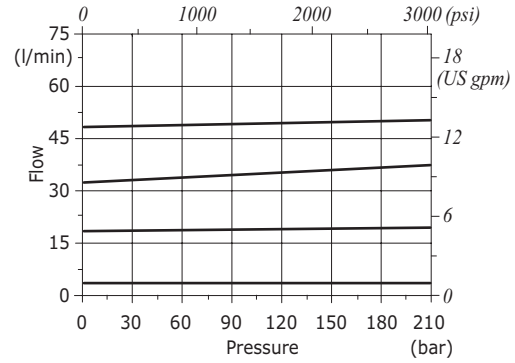

VPR/3/ET 34 compensation diagram E-> C

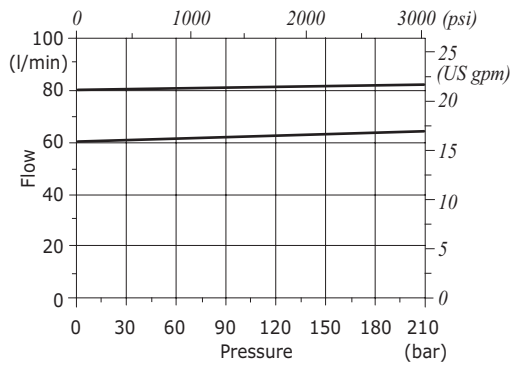

VPR/3/ET 100 compensation diagram E-> C

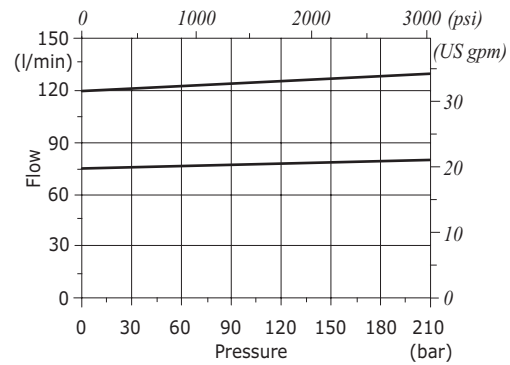

VPR/3/ET 114 compensation diagram E-> C

