



## Type VRDE..CIL pilot operated check valves

- Double acting
- With bolt connection

Technical specifications and diagrams are measured with mineral oil of 46 cSt viscosity at 40°C (104°F) temperature.

	VRDE01CIL	VRDE02CIL
Nominal flow	20 l/min (5.3 US gpm)	
Max. pressure	300 bar (4350 psi)	
Oil leakage	0.25 cm <sup>3</sup> /min (0.015 in <sup>3</sup> /min) at 210 bar (3050 psi)	
Fluid	mineral based oil	
Viscosity	from 10 to 200 cSt	
Max. level of contamination	18/16/13 ISO4406	
Fluid temperature	with NBR seals from -20°C (-4°F) to 80°C (176°F)	
Environmental temp. for working conditions	from -40°C (-40°F) to 100°C (212°F)	
Weight	Steel 0.45 kg (0.99 lb)	0.65 kg (1.43 lb)

NOTE - For different conditions, please contact Walvoil Sales Dpt.

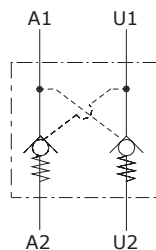

### Dimensions

Valve type	All ports
VRDE01CIL	G1/4
VRDE02CIL	G3/8

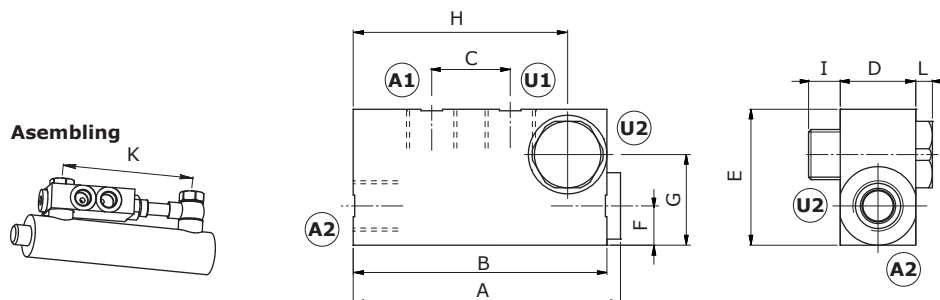

Dimensions are in mm-in

Valve type	A	B	C	D	E	F	G	H	I	L	K min
VRDE01CIL	88.5-3.48	84-3.31	24-0.94	20-0.79	40-1.57	10-0.39	27-1.06	68.5-2.7	10-0.39	6-0.23	123-4.84
VRDE02CIL	90.5-3.56	86-3.38	26-1.02	25-0.98	45-1.77	12-0.47	31-1.22	72-2.83	11-0.43	7-0.27	127-5

### Ordering codes and description composition

Port size  
VRDE 02 CIL

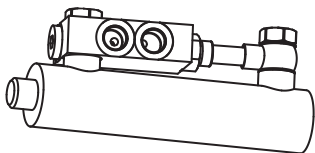

#### VRDECIL complete valves

TYPE	CODE	DESCRIPTION
VRDE01CIL	1420312100	Steel body, G1/4 port, opening pressure 1 bar (14,5 psi), pilot ratio 1:4.9
VRDE02CIL	1420322100	Steel body, G3/8 port, opening pressure 1 bar (14,5 psi), pilot ratio 1:4.9

For different configurations or SAE threads please contact our Sales Dpt.

### Rating diagram

