



# 201 SERIES VCR



Designed for elevation systems on trucks.  
Reduced drop pressure.  
Poppet Valve closing system.

- **Materials**

Carbon Steel EN10277-3

O-ring: **NBR, Viton or EPDM**

Springs: Carbon Steel DIN 17233/84(B)

- **Working temperature (O-ring)**

	NBR	Viton	EPDM
	+100°C	+200°C	+150°C
	-30°C	-10°C	-40°C

- **Applications:** Designed for Oil hydraulic Applications  
Hammer Application

- **Sectors:** Industrial



- **Equivalence:** FASTER CVE  
EDBRO

## MODEL STRUCTURE

Example:

**201.11114 AE**

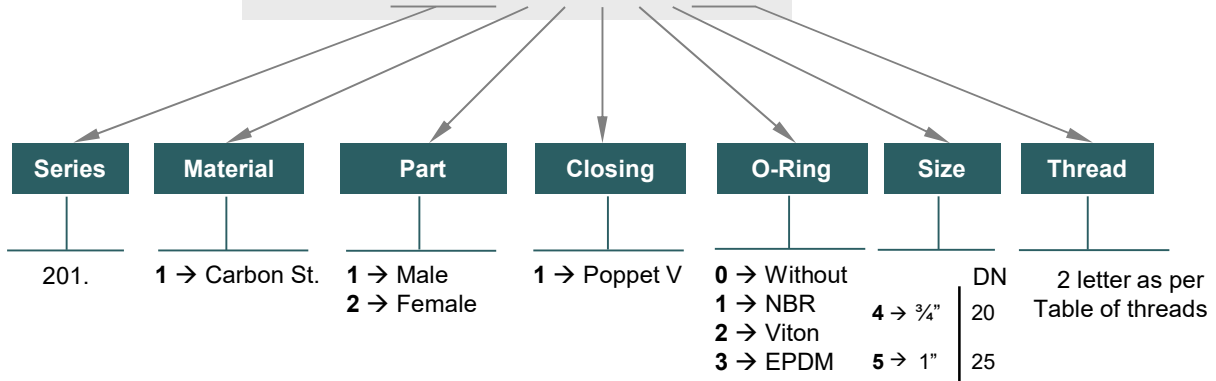

**201-1**

# 201 SERIES VCR

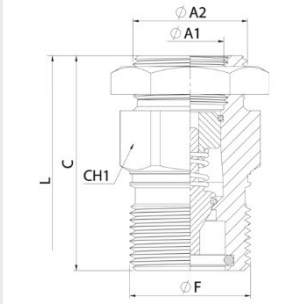

## MALE

DN	ØA1	ØA2	CH1	C	ØF	L	REF.	
20	3/4" BSP	1 1/4"	46	78	44	138	201.11114AE	350 Bar
25	1" BSP	BSP	55	83	53,60	148	201.11115AF	300 Bar

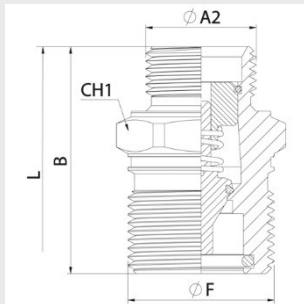

## MALE

DN	ØA2	CH1	B	ØF	L	REF.	
20	1" BSP	46	68	44	118,50	201.11114AQ	350 Bar

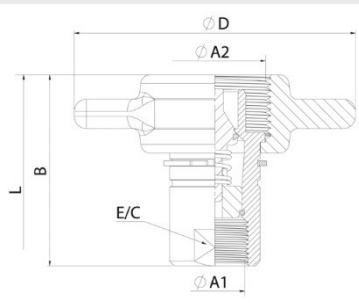

## FEMALE

DN	ØA1	ØA2	E/C	B	ØD	L	REF.	
20	3/4" BSP	41,50	33	78	115	138	201.12114AE	350 Bar
25	1" BSP	51	40	83	115	148	201.12115AF	300 Bar

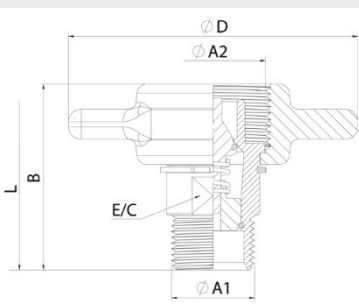

## FEMALE

DN	ØA1	E/C	ØA2	B	ØD	L	REF.	
20	1" BSP	33	41,50	74	115	118,50	201.12114AQ	350 Bar



# 201 SERIES VCR



## TECHNICAL DATA

DN	Rated Flow	Min Burst Pressure (bar)			Max. Working Pressure
		Male	Female	Coupled	
20	120 l/m	1100	1300	1325	350 bar
25	160 l/m	1200	900	1325	300 bar

Test performed according to ISO 18869

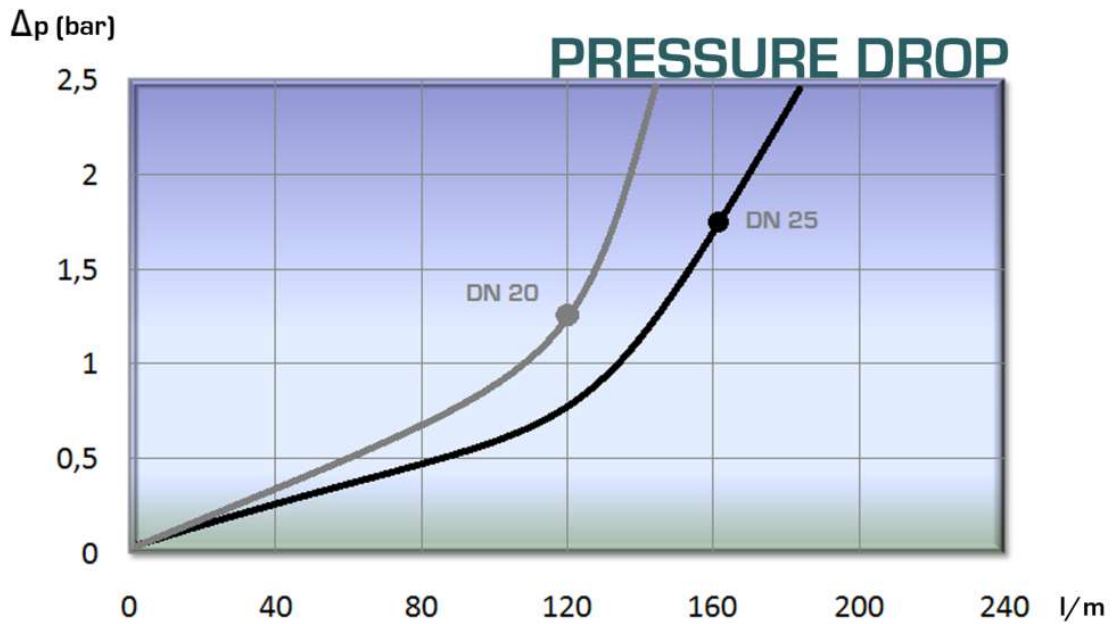



# 201 SERIES VCR PLUGS & CAPS



## MODEL STRUCTURE

For plugs/caps and parking parts

Example:

### 201.6304 AA

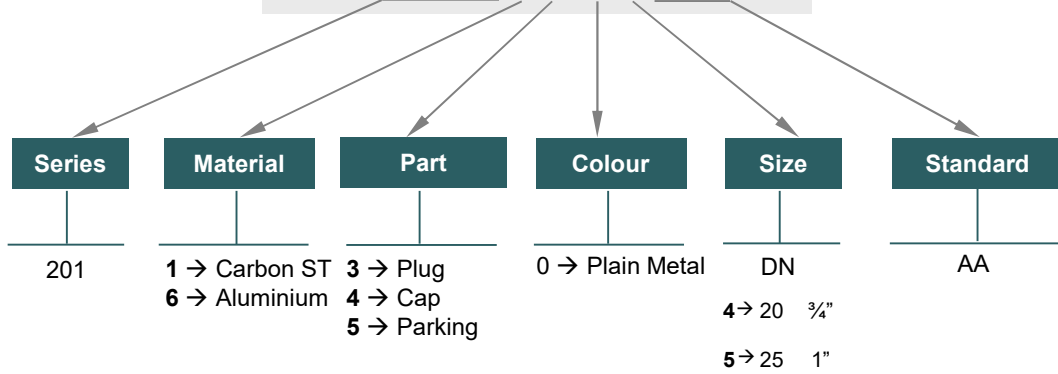

DN	REF.	ØA	L	B	ØD
20	201.6304AA	50	200	25	37,5
25	201.6305AA	60	191	25	42

DN	REF.	ØA	L	B	ØD
20	201.6404AA	48	191	13	42
25	201.6405AA	60	191	18	52

DN	REF.	ØA	L
20	201.1504AA	45	25
25	201.1505AA	55	25